

# FFBall Valves

Full Flow Ball Valves



## Product Information

# KilltheSpill

## About Mann Tek

Mann Teknik AB is a Swedish company located in Mariestad, Sweden.

Mann Teknik AB produces and markets products for safe and environmentally friendly handling of aggressive fluids for the chemical and petrochemical industries.

The main product is the Dry Disconnect Couplings, DDCouplings®, for spill free liquid handling. The products are marketed through independent representatives in more than 30 countries.

Mann Teknik AB have many years of experience in designing, producing and marketing of DDCouplings® all since 1977.

Mann Teknik AB has shown a high rate of growth during the past years and is now a major player in its specialized field of operation. This is due to a determined expansion into growing markets and recognition by customers of the robust design and reliable quality of the products.

Mann Teknik AB are certified to ISO9001:2008. The products are CE-labeled. The main products are certified to PED, the European Pressure Equipment Directive and ATEX, the European directive for Equipment intended for use in Potentially Explosive Atmospheres.

The products are produced in accordance with several important standards, e.g. the NATO STANAG 3756



# KilltheSpill



## Table of Contents

Company Information	2
Introduction and summary - Full Flow Ball Valves / 2-ways Ball Valves	4
General Information Full Flow Ball Valves	5
Advantages - Ball Valve / 2-way Valve in Aluminium	6
Ball Valve - Exploded view	7
2-way Valve - Exploded view	8
Table - Ball Valves in Aluminium	9
Table - 2-way Valves in Aluminium	10
Table - Ball Valves with pneumatic springreturn	11
Table - Ball Valves with pneumatic actuator double acting	12
Table - 2-way Valves with pneumatic actuator double acting	13
Ball Valves / 2-way Valves in Aluminium without flanges	14
Ball Valves / 2-way Valves in Aluminium. Female BSP threaded Aluminium flange	15
Ball Valves / 2-way Valves in Aluminium. Female BSP threaded Steel flange	16
Ball Valves / 2-way Valves in Aluminium. Female NPT threaded Aluminium flange	17
Ball Valves / 2-way Valves in Aluminium. Male BSP threaded Aluminium flange	18
Ball Valves / 2-way Valves in Aluminium. Male BSP threaded Steel flange	19
Ball Valves / 2-way Valves in Aluminium. Welding Steel flange 60/89/114 mm	20
Ball Valves / 2-way Valves in Aluminium. Welding Stainless Steel flange 60/89 mm	21
Ball Valves / 2-way Valves in Aluminium. Flat welding Aluminium flange. 57/76/108 mm	22
Ball Valves / 2-way Valves in Aluminium. Welding Steel flange. 76/102 mm	23
Ball Valves / 2-way Valves in Aluminium. TW flange in Aluminium.	24
Ball Valves / 2-way Valves in Aluminium/Stainless Steel Victaulic ANSI AWWA C-606	25
Ball Valves / 2-way Valves in Aluminium. DN 80/ DN 100 PN 10/16	26
Ball Valves with DN 50 TW1 flange in Aluminium - Special compact	27
Ball Valves / 2-way Valves in Aluminium with pneumatic actuator double acting	28
Ball Valves in Aluminium with pneumatic actuator springreturn	29
Ball Valves - Special on request	30-31
2" / DN 50 flanges	32-38
3" / DN 80 flanges	39-46
4" / DN 100 flanges	47-54
Flange Measurement	55-56
Pressure Drop Measurement	57
Flow Diagram -Pressure Drop	58
Efficient design pneumatic actuators	59
Operation actuators	60
Technical specification pneumatic actuators	61-62
Accessories - pneumatic actuators	63-64
Electric actuators	65-68
Flat Seals for thred	69-70
About NPT and BSP threads	71
Explanation of designations	72-73
How to Order / Questionnaire	74
Service - Maintenance and service instruction	75
Repair service and certificate of decontamination	76
Other Products / Approvals / Your Distributor	80

## Ball Valves / 2-way Ball Valves in Aluminium

Full Flow Ball Valves and 2-way Ball Valves are specially designed for handling different types of fuels such as diesel, gasoline, Jet fuel etc. in Tank trucks. Mann Tek Ball Valves in Aluminium offer weight saving benefits to the road tanker industry and they are also used in different types of fixed plant and mobile fuelling applications.

All sizes of Mann Tek Ball Valves and 2-way Valves are available with pneumatic actuation in either single or double acting form.

### Sizes

2" (DN 50) to 4" (DN 100)

### Connections:

Full Flow ball Valves and 2-way Ball Valves are available with BSP- and NPT-threads and with flanges (DIN, ANSI, TW, TTMA, EN 1092-1:2001).

### Maximum Working Pressure:

MWP PN 10  
MAWP 150 psi

### Material:

**Body:** Aluminium  
**Ball:** Aluminium  
**Spindle:** Stainless Steel

### Seals:

Teflon® (PTFE), Viton® (FPM).  
Other Seals on request.

### Working temperature - Seals material

Lowest Operation Temperature:

With Seals Material:	Lowest Temperature:
FPM (Standard Viton)	-20° C / -4° F
NBR	-25° C / -13° F
Low temperature NBR	-40° C / -40° F
FQM (Flourosilicon)	-55° C / -67° F

*These materials must be tried individually and are subject to no obligation. Always check with chemical compability chart before use. Used with for example: Petrol, diesel, aviation fuel.*

### Recommendations and approvals:



#### Ball Valves in Aluminium.



#### 2-way Ball Valves in Aluminium.



#### Ball Valves in Aluminium with pneumatic actuator (springreturn or double acting).



#### 2-way Ball Valves in Aluminium with pneumatic actuator double acting.

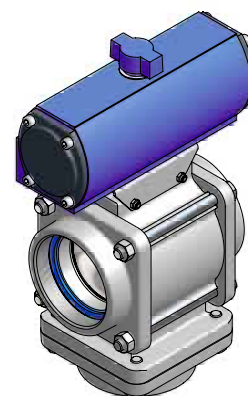

## Business segment - Ball Valves



**Aviation**



**Tank Trucks**



**Military**

## General information Full Flow Ball Valves

### Advantages

- Unflattened flanges do not affect the balls torque.
- All wetted parts in: Aluminium, Stainless Steel, FPM (Viton®), PTFE (Teflon®). No Yellow parts.
- The sealing stays in its position also when you are regulating high flowrates.
- Low pressure drop.
- Easy to service: The spindle can easily be dismantled, even if the ball valve is installed.
- The valve is assembled as one unit - not kept together by the flanges.
- Inbuilt measurements as common standard.

### Apragaz Type approval

**Ball Valves acc. to ADR, RID, IMDG**  
**2-way Valves acc. to ADR, RID, IMDG**



### Applications for Ball Valves

- Petroleum tank trucks
- Tank trucks for solvents
- Dispenser and Tank trucks for aircraft refuelling
- Stationary and mobile equipment for aircraft refuelling
- Valves for the paint industry
- Valves for the oil industry
- Waste water for railwaggons





## Advantages - Ball Valve in Aluminium

The spindle can easily be dismantled even when the ball valve is installed.

Pneumatic actuators available for all sizes, 90° operating, single/double acting.

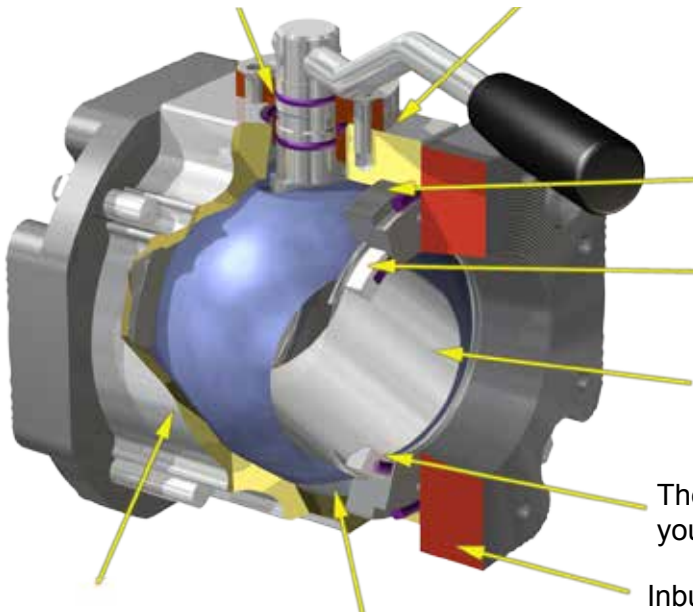

Irregular or crowned flanges do not affect the ball torque.

All wetted parts in Aluminium and Stainless Steel, Sealings in FPM (Viton®) and PTFE (Teflon®).

The biggest run of all brands.

The sealing stays in its position also when you are regulating high pressure drop.

Inbuilt measurements replace other brands

The valve is assembled as one unit - not kept together by the flanges

Minimum liquid remains in the ball valve

## Advantages - 2-way Ball Valve in Aluminium

The spindle can easily be dismantled even when the ball valve is installed.

Pneumatic actuators available for all sizes, 180° operating, single/double acting.

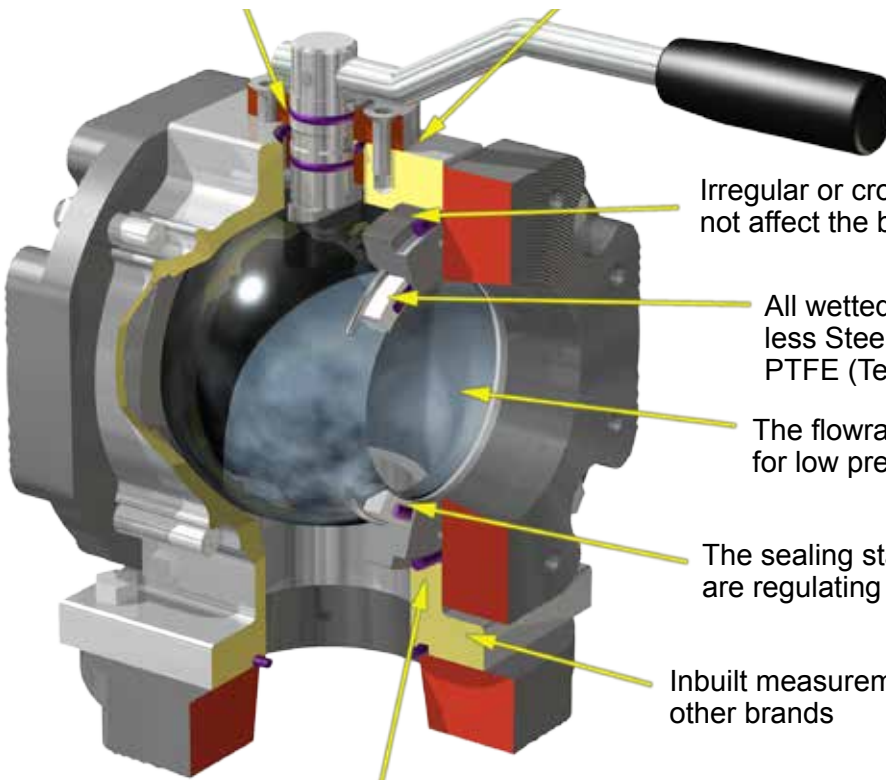

Irregular or crowned flanges do not affect the ball torque.

All wetted parts in Aluminium and Stainless Steel, Sealings in FPM (Viton®) and PTFE (Teflon®).

The flowrate through the ball is optimized for low pressure drop.

The sealing stays in its position also when you are regulating high pressure drop.

Inbuilt measurements replace other brands

The valve is assembled as one unit - not kept together by the flanges

# Ball Valve - Exploded view

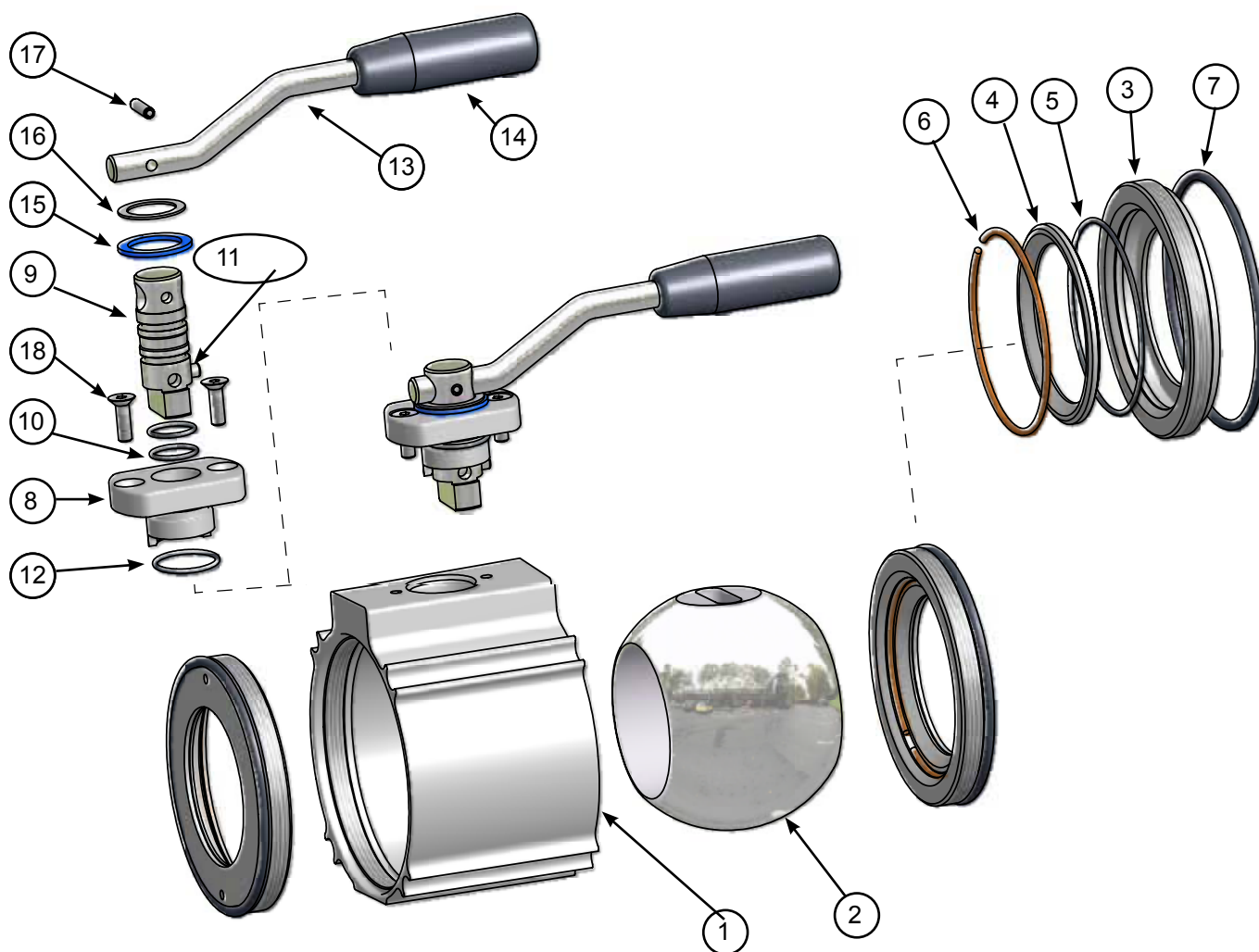

No	Description	Material	Quantity
001	BV-BODY 3"	ALUMINIUM	1.0
002	BALL 3"	ALUMINIUM	1.0
003	SUPPORT RING 3"	ALUMINIUM	2.0
004	SEALING RING 3"	PTFE (Teflon® )	2.0
005	O-RING	FPM (Viton®)	2.0
006	SECURE RING 3"	Stainless steel	2.0
007	O-RING	FPM (Viton®)	2.0
008	SPINDLE GUIDE	Stainless steel	1.0
009	SPINDLE	Stainless steel	1.0
010	O-RING	FPM (Viton®)	2.0
011	CYLINDRICAL PIN	Stainless steel	1.0
012	O-RING	FPM (Viton®)	1.0
013	LEVER	Stainless Steel	1.0
014	HANDLE	PLASTIC	1.0
015	FLAT SEAL 1"	PUR (Vulkollan®)	1.0
016	WASHER	Stainless Steel	1.0
017	TENSION PIN	Stainless steel	1.0
018	SCREW	Stainless steel	2.0

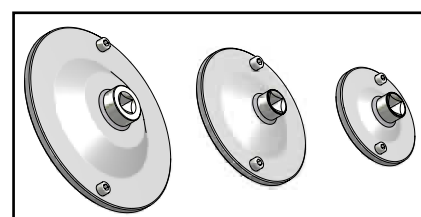

Mounting tools for support ring.

## 2-way Valve - Exploded view

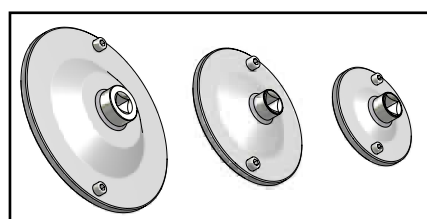
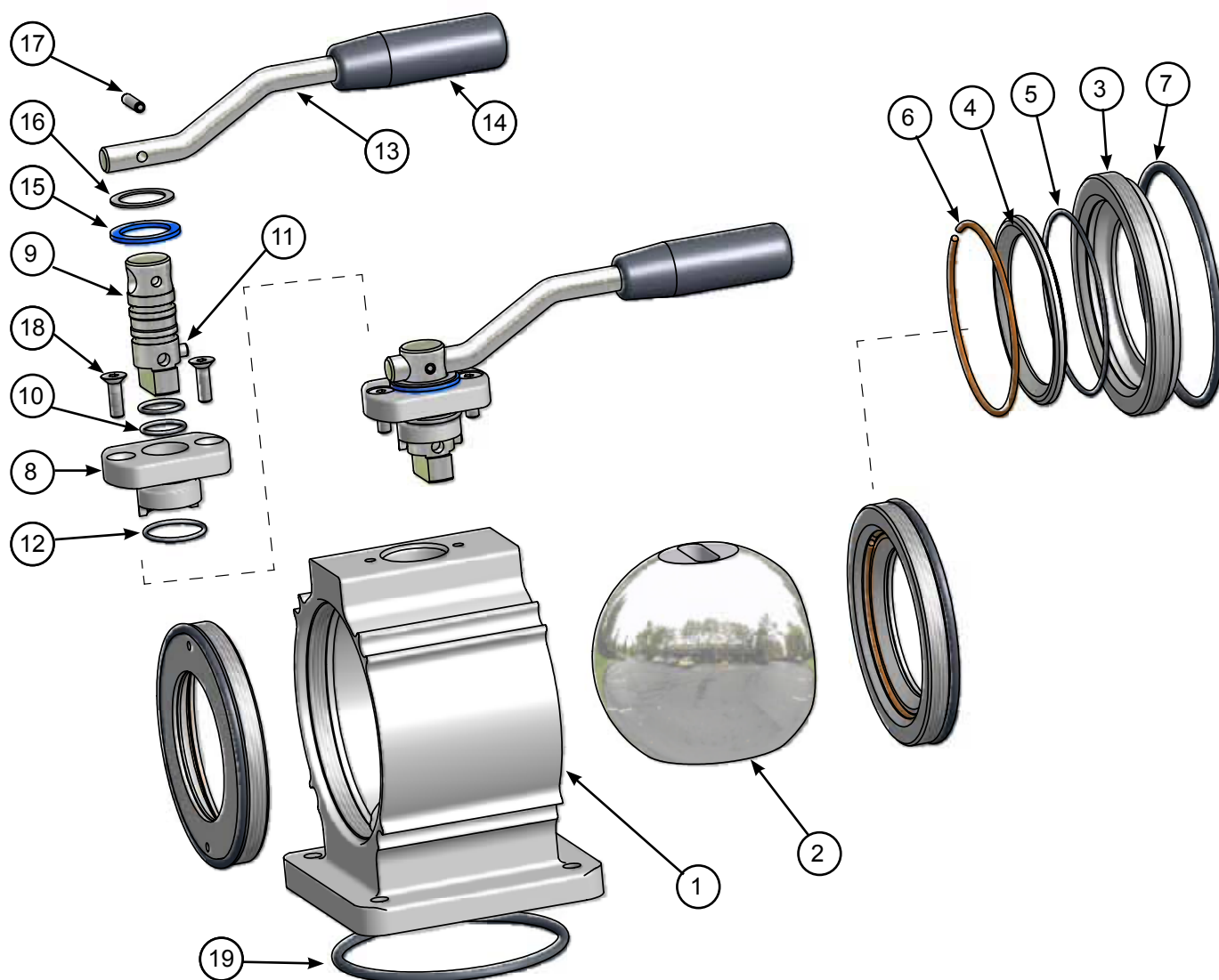

**Mounting tools  
for support ring.**

No	Description	Material	Quantity
001	BV-BODY 3" 2WAY	ALUMINIUM	1.0
002	BALL 3" 2 WAY	ALUMINIUM	1.0
003	SUPPORT RING 3"	ALUMINIUM	2.0
004	SEALING RING 3"	PTFE (Teflon®)	2.0
005	O-RING	FPM (Viton®)	2.0
006	SECURE RING 3"	Stainless steel	2.0
007	O-RING	FPM (Viton®)	2.0
008	SPINDLE GUIDE	Stainless steel	1.0
009	SPINDLE	Stainless steel	1.0
010	O-RING	FPM (Viton®)	2.0
011	CYLINDRICAL PIN	Stainless steel	1.0
012	O-RING	FPM (Viton®)	1.0
013	LEVER	Stainless Steel	1.0
014	HANDLE	PLASTIC	1.0
015	FLAT SEAL 1"	PUR (Vulkollan®)	1.0
016	WASHER	Stainless Steel	1.0
017	TENSION PIN	Stainless steel	1.0
018	SCREW	Stainless steel	2.0
019	O-RING	FPM (Viton®)	1.0

Viton® and Teflon® are registered Trademarks by Du Pont



## Ball Valves in Aluminium

**Description:** Ball Valves Dim DN 50-100 / 2"-4", W.P 10 bar / 150 PSI.

Flanges available in aluminium or steel. Flange seal in Viton® (FPM). Ball seal in Teflon® (PTFE).

Other materials and connection on request.

Inch DN <sup>1)</sup>	Connection <sup>2)</sup>	Mtrl. Flange <sup>3)</sup>	Weight kg	Code No.	Illustration
2" DN 50	-	-	1,4	B200A1001	<b>Material</b>  <b>Body:</b> Aluminium <b>Ball:</b> Aluminium <b>Spindle:</b> Stainless Steel <b>Sealing:</b> Teflon® (PTFE), Viton® (FPM)
	BSP 2" F	Al	2,2	B210A1101	
		St	2,6	B210A1301	
	NPT 2" F	Al	2,3	B211A1101	
	BSP 2" M	Al	2,0	B278A1101	
	W Ø57 mm / 2.24 inch	Al	2,0	B289A1101	
		St	2,4	B290A1301	
	W Ø60 mm / 2.36 inch	SS	2,5	B290A1401	
Al		3,3	B287A1101		
3" DN 80	-	-	2,4	B400A1001	
	BSP 3" F	Al	-	B414A1101	
		St	4,7	B414A1301	
	NPT 3" F	Al	4	B415A1101	
	BSP 3" M	Al	3,8	B482A1101	
		St	4,7	B482A1301	
	W Ø76 mm / 2.99 inch	Al	3,9	B492A1101	
		St	-	B492A1301	
	W Ø89 mm / 3.50 inch	Al	3,8	B493A1101	
		St	5,4	B493A1301	
		SS	5,8	B493A1401	
	TW1 / 80	Al	5,5	B465A1101	
	DN 65 PN 10/16	Al	-	B433A1101	
	DN 80 PN 10/16	Al	5,4	B436A1101	
2½" ANSI 150 PSI	Al	-	B459A1101		
3" ANSI 150 psi	Al	5,9	B461A1101		
4" DN 100	-	-	5,2	B500A1001	
	BSP 4" F	Al	7,1	B516A1101	
		St	10	B516A1301	
	NPT 4" F	Al	7,5	B517A1101	
	BSP 4" M	Al	7,5	B584A1101	
		St	10	B584A1301	
	W Ø 102 mm / 4.02 inch	St	-	B595A1301	
	W Ø 108 mm / 4.25 inch	Al	6,7	B596A1101	
	W Ø 114 mm / 4.49 inch	St	9,6	B597A1301	
	TW3 / 100	Al	8	B566A1101	
	DN 100 PN 10/16	Al	9,6	B539A1101	
4" ANSI 150 PSI	Al	10	B563A1101		



1) Dimension Ball Valves

3) Mtrl:St=Steel, Al=Aluminium, SS=Stainless steel

2) F=Female thread

M=Male thread, W=Flange for welding

Threads: BSP=ISO 228, NPT=ANSI B1.20.3

Viton® (FPM) and Teflon® (PTFE) are registered trademarks of DuPont.

## 2-way Ball Valves in Aluminium

**Description:** Ball Valves Dim DN 50-100 / 2"-4", W.P 10 bar / 150 PSI.

Flanges available in aluminium or steel. Flange seal in Viton® (FPM). Ball seal in Teflon® (PTFE).

Other materials and connection on request.

Inch DN <sup>1)</sup>	Connection <sup>2)</sup>	Mtrl. Flange <sup>3)</sup>	Weight kg	Code No.	Illustration
2" DN 50	-	-	1,6	B200A1001C	<b>Material</b>  <b>Body:</b> Aluminium <b>Ball:</b> Aluminium <b>Spindle:</b> Stainless Steel <b>Sealing:</b> Teflon® (PTFE), Viton® (FPM)
	BSP 2" F	Al	2,7	B210A1101C	
		St	3,5	B210A1301C	
	NPT 2" F	Al	2,8	B211A1101C	
	BSP 2" M	Al	2,5	B278A1101C	
	W Ø57 mm / 2.24 inch	Al	2,7	B289A1101C	
	W Ø60 mm / 2.36 inch	St	3,3	B290A1301C	
		SS	3,3	B290A1401C	
TW1 / 50	Al	4,4	B287A1101C		
3" DN 80	-	-	3,1	B400A1001C	
	BSP 3" F	Al	-	B414A1101C	
		St	6,4	B414A1301C	
	NPT 3" F	Al	5,4	B415A1101C	
	BSP 3" M	Al	5	B482A1101C	
		St	6,8	B482A1301C	
	W Ø76 mm / 2.99 inch	Al	5,1	B492A1101C	
		St	-	B492A1301C	
	W Ø89 mm / 3.50 inch	Al	5,1	B493A1101C	
		St	6,5	B493A1301C	
		SS	7,5	B493A1401C	
	TW1 / 80	Al	7,5	B465A1101C	
	DN 65 PN 10/16	Al	?	B433A1101C	
DN 80 PN 10/16	Al	-	B436A1101C		
2½" ANSI 150 PSI	Al	?	B459A1101C		
3" ANSI 150 psi	Al	8,1	B461A1101C		
4" DN 100	-	-	5,8	B500A1001C	
	BSP 4" F	Al	8,6	B516A1101C	
		St	13	B516A1301C	
	NPT 4" F	Al	9,1	B517A1101C	
	BSP 4" M	Al	9,1	B584A1101C	
		St	12,9	B584A1301C	
	W Ø 102 mm / 4.02 inch	St	-	B595A1301C	
	W Ø 108 mm / 4.25 inch	Al	8	B596A1101C	
	W Ø 114 mm / 4.49 inch	St	12,5	B597A1301C	
	TW3 / 100	Al	10	B566A1101C	
DN 100 PN 10/16	Al	12,1	B539A1101C		



1) Dimension Ball Valves

3) Mtrl:St=Steel, Al=Aluminium, SS=Stainless steel

2) F=Female thread

M=Male thread, W=Flange for welding

Threads: BSP=ISO 228, NPT=ANSI B1.20.3

Viton® (FPM) and Teflon® (PTFE) are registered trademarks of DuPont.

## Ball Valves in Aluminium with pneumatic actuator springreturn

**Description:** Ball Valves Dim DN 50-100 / 2"-4", W.P 10 bar / 150 PSI.

Flanges available in aluminium or steel. Flange seal in Viton® (FPM). Ball seal in Teflon® (PTFE). Other materials and connection on request.

ATEX approved



Inch DN <sup>1)</sup>	Connection <sup>2)</sup>	Mtrl. Flange <sup>3)</sup>	Weight kg	Code No.	Illustration
2" DN 50	-	-	-	B200A1001-SR	<b>Material</b>  <b>Body:</b> Aluminium <b>Ball:</b> Aluminium <b>Spindle:</b> Stainless Steel <b>Sealing:</b> Teflon® (PTFE), Viton® (FPM)
	BSP 2" F	Al	-	B210A1101-SR	
		St	-	B210A1301-SR	
	NPT 2" F	Al	-	B211A1101-SR	
	BSP 2" M	Al	-	B278A1101-SR	
	W Ø57 mm / 2.24 inch	Al	-	B289A1101-SR	
	W Ø60 mm / 2.36 inch	St	-	B290A1301-SR	
		SS	-	B290A1401-SR	
TW1 / 50	Al	-	B287A1101-SR		
3" DN 80	-	-	5,7	B400A1001-SR	
	BSP 3" F	Al	-	B414A1101-SR	
		St	7,6	B414A1301-SR	
	NPT 3" F	Al	6,9	B415A1101-SR	
	BSP 3" M	Al	6,7	B482A1101-SR	
		St	7,6	B482A1301-SR	
	W Ø76 mm / 2.99 inch	Al	6,8	B492A1101-SR	
		St	-	B492A1301-SR	
	W Ø89 mm / 3.50 inch	Al	6,7	B493A1101-SR	
		St	8,2	B493A1301-SR	
		SS	8,6	B493A1401-SR	
	TW1 / 80	Al	8,4	B465A1101-SR	
	DN 65 PN 10/16	Al	-	B433A1101-SR	
	DN 80 PN 10/16	Al	8,3	B436A1101-SR	
2½" ANSI 150 PSI	Al	-	B459A1101-SR		
3" ANSI 150 psi	Al	8,8	B461A1101-SR		
4" DN 100	-	-	8,4	B500A1001-SR	
	BSP 4" F	Al	9,8	B516A1101-SR	
		St	12,7	B516A1301-SR	
	NPT 4" F	Al	10,2	B517A1101-SR	
	BSP 4" M	Al	10,2	B584A1101-SR	
		St	12,7	B584A1301-SR	
	W Ø 102 mm / 4.02 inch	St	-	B595A1301-SR	
	W Ø 108 mm / 4.25 inch	Al	9,45	B596A1101-SR	
	W Ø 114 mm / 4.49 inch	St	12,4	B597A1301-SR	
	TW3 / 100	Al	10,7	B566A1101-SR	
	DN 100 PN 10/16	Al	12,3	B539A1101-SR	
4" ANSI 150 PSI	Al	12,7	B563A1101-SR		



1) Dimension Ball Valves

3) Mtrl:St=Steel, Al=Aluminium, SS=Stainless steel

2) F=Female thread

M=Male thread, W=Flange for welding

Threads:BSP=ISO 228, NPT=ANSI B1.20.3

Viton® (FPM) and Teflon® (PTFE) are registered trademarks of DuPont.



## Ball Valves in Aluminium with pneumatic actuator double acting

**Description:** Ball Valves Dim DN 50-100 / 2"-4", W.P 10 bar / 150 PSI.

Flanges available in aluminium or steel. Flange seal in Viton® (FPM). Ball seal in Teflon® (PTFE). Other materials and connection on request.

ATEX approved



Inch DN <sup>1)</sup>	Connection <sup>2)</sup>	Mtrl. Flange <sup>3)</sup>	Weight Kg	Code No.	Illustration
2" DN 50	-	-	-	B200A1001-DA	<b>Material</b>  <b>Body:</b> Aluminium <b>Ball:</b> Aluminium <b>Spindle:</b> Stainless Steel <b>Sealing:</b> Teflon® (PTFE), Viton® (FPM)
	BSP 2" F	Al	-	B210A1101-DA	
		St	-	B210A1301-DA	
	NPT 2" F	Al	-	B211A1101-DA	
	BSP 2" M	Al	-	B278A1101-DA	
	W Ø57 mm / 2.24 inch	Al	-	B289A1101-DA	
	W Ø60 mm / 2.36 inch	St	-	B290A1301-DA	
		SS	-	B290A1401-DA	
TW1 / 50	Al	-	B287A1101-DA		
3" DN 80	-	-	5,7	B400A1001-DA	
	BSP 3" F	Al	-	B414A1101-DA	
		St	7,6	B414A1301-DA	
	NPT 3" F	Al	6,9	B415A1101-DA	
	BSP 3" M	Al	6,7	B482A1101-DA	
		St	7,6	B482A1301-DA	
	W Ø76 mm / 2.99 inch	Al	6,8	B492A1101-DA	
		St	-	B492A1301-DA	
	W Ø89 mm / 3.50 inch	Al	6,7	B493A1101-DA	
		St	8,2	B493A1301-DA	
		SS	8,6	B493A1401-DA	
	TW1 / 80	Al	8,4	B465A1101-DA	
	DN 65 PN 10/16	Al	-	B433A1101-DA	
	DN 80 PN 10/16	Al	8,3	B436A1101-DA	
2½" ANSI 150 PSI	Al	-	B459A1101-DA		
3" ANSI 150 psi	Al	8,8	B461A1101-DA		
4" DN 100	-	-	8,4	B500A1001-DA	
	BSP 4" F	Al	9,8	B516A1101-DA	
		St	12,7	B516A1301-DA	
	NPT 4" F	Al	10,2	B517A1101-DA	
	BSP 4" M	Al	10,2	B584A1101-DA	
		St	12,7	B584A1301-DA	
	W Ø 102 mm / 4.02 inch	St	-	B595A1301-DA	
	W Ø 108 mm / 4.25 inch	Al	9,45	B596A1101-DA	
	W Ø 114 mm / 4.49 inch	St	12,4	B597A1301-DA	
	TW3 / 100	Al	10,7	B566A1101-DA	
	DN 100 PN 10/16	Al	12,3	B539A1101-DA	
	4" ANSI 150 PSI	Al	12,7	B563A1101-DA	



1) Dimension Ball Valves

3) Mtrl:St=Steel, Al=Aluminium, SS=Stainless steel

2) F=Female thread

M=Male thread, W=Flange for welding

Threads:BSP=ISO 228, NPT=ANSI B1.20.3

Viton® (FPM) and Teflon® (PTFE) are registered trademarks of DuPont.

## 2-way Ball Valves in Aluminium with pneumatic actuator double acting

**Description:** Ball Valves Dim DN 50-100 / 2"-4", W.P 10 bar / 150 PSI.

Flanges available in aluminium or steel. Flange seal in Viton® (FPM). Ball seal in Teflon® (PTFE). Other materials and connection on request.

ATEX approved



Inch DN <sup>1)</sup>	Connection <sup>2)</sup>	Mtrl. Flange <sup>3)</sup>	Weight kg	Code No.	Illustration
<b>2" DN 50</b>	-	-	4,6	<b>B200A1001C-DA</b>	<b>Material</b>  <b>Body:</b> Aluminium <b>Ball:</b> Aluminium <b>Spindle:</b> Stainless Steel <b>Sealing:</b> Teflon® (PTFE), Viton® (FPM)
	BSP 2" F	Al	4,9	<b>B210A1101C-DA</b>	
		St	6,3	<b>B210A1301C-DA</b>	
	NPT 2" F	Al	5,8	<b>B211A1101C-DA</b>	
	BSP 2" M	Al	5,3	<b>B278A1101C-DA</b>	
	W Ø57 mm / 2.24 inch	Al	5,3	<b>B289A1101C-DA</b>	
	W Ø60 mm / 2.36 inch	St	6,0	<b>B290A1301C-DA</b>	
		SS	6,1	<b>B290A1401C-DA</b>	
TW1 / 50	Al	7,2	<b>B287A1101C-DA</b>		
<b>3" DN 80</b>	-	-	5,6	<b>B400A1001C-DA</b>	
	BSP 3" F	Al	-	<b>B414A1101C-DA</b>	
		St	8,5	<b>B414A1301C-DA</b>	
	NPT 3" F	Al	7,5	<b>B415A1101C-DA</b>	
	BSP 3" M	Al	7,5	<b>B482A1101C-DA</b>	
		St	8,5	<b>B482A1301C-DA</b>	
	W Ø76 mm / 2.99 inch	Al	7,3	<b>B492A1101C-DA</b>	
		St	-	<b>B492A1301C-DA</b>	
	W Ø89 mm / 3.50 inch	Al	7,2	<b>B493A1101C-DA</b>	
		St	9,5	<b>B493A1301C-DA</b>	
		SS	10,1	<b>B493A1401C-DA</b>	
	TW1 / 80	Al	9,8	<b>B465A1101C-DA</b>	
	DN 65 PN 10/16	Al	-	<b>B433A1101C-DA</b>	
	DN 80 PN 10/16	Al	9,6	<b>B436A1101C-DA</b>	
	2½" ANSI150 PSI	Al	-	<b>B459A1101C-DA</b>	
3" ANSI 150 psi	Al	10,3	<b>B461A1101C-DA</b>		
<b>4" DN 100</b>	-	-	9,9	<b>B500A1001C-DA</b>	
	BSP 4" F	Al	12,2	<b>B516A1101C-DA</b>	
		St	16,5	<b>B516A1301C-DA</b>	
	NPT 4" F	Al	12,7	<b>B517A1101C-DA</b>	
	BSP 4" M	Al	12,7	<b>B584A1101C-DA</b>	
		St	16,5	<b>B584A1301C-DA</b>	
	W Ø 102 mm / 4.02 inch	St	-	<b>B595A1301C-DA</b>	
	W Ø 108 mm / 4.25 inch	Al	11,6	<b>B596A1101C-DA</b>	
	W Ø 114 mm / 4.49 inch	St	15,9	<b>B597A1301C-DA</b>	
	TW3 / 100	Al	13,4	<b>B566A1101C-DA</b>	
DN 100 PN 10/16	Al	16,5	<b>B539A1101C-DA</b>		



1) Dimension Ball Valves

3) Mtrl:St=Steel, Al=Aluminium, SS=Stainless steel

2) F=Female thread

M=Male thread, W=Flange for welding

Threads:BSP=ISO 228, NPT=ANSI B1.20.3

## Ball Valves in Aluminium without flanges

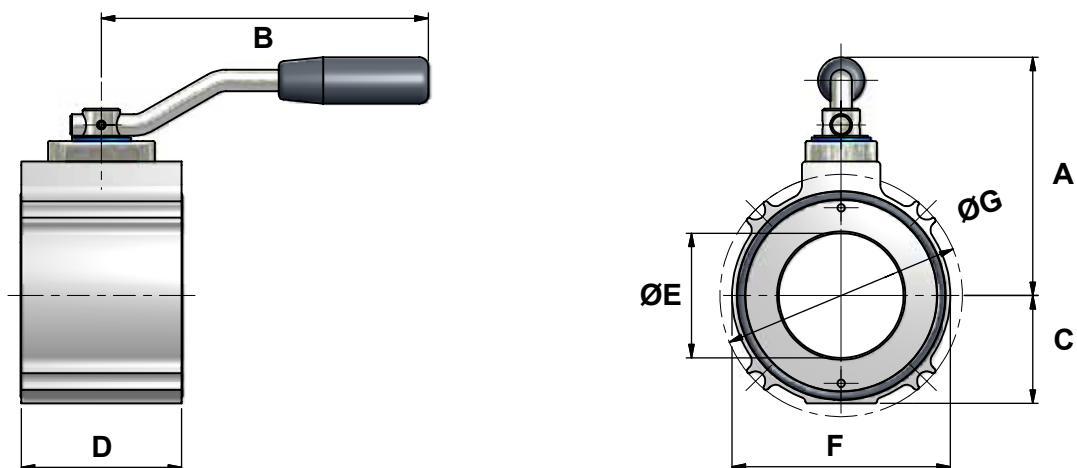

All measurements in mm/inch

Inch DN		A	B	C	D	ØE	F	ØG	Code No.
<b>2" / DN 50</b>	mm	116	200	45	65	45	90	99	<b>B200A1001</b>
	inch	4.57	7.87	1.77	2.56	1.77	3.54	3.90	
<b>3" / DN 80</b>	mm	134	200	61	90	70	123	136	<b>B400A1001</b>
	inch	5.28	7.87	2.41	3.54	2.76	4.84	5.35	
<b>4" / DN 100</b>	mm	156	200	85	125	98	169	179	<b>B500A1001</b>
	inch	6.14	7.87	3.35	4.92	3.86	2.72	7.05	

## 2-way Valves in Aluminium without flanges

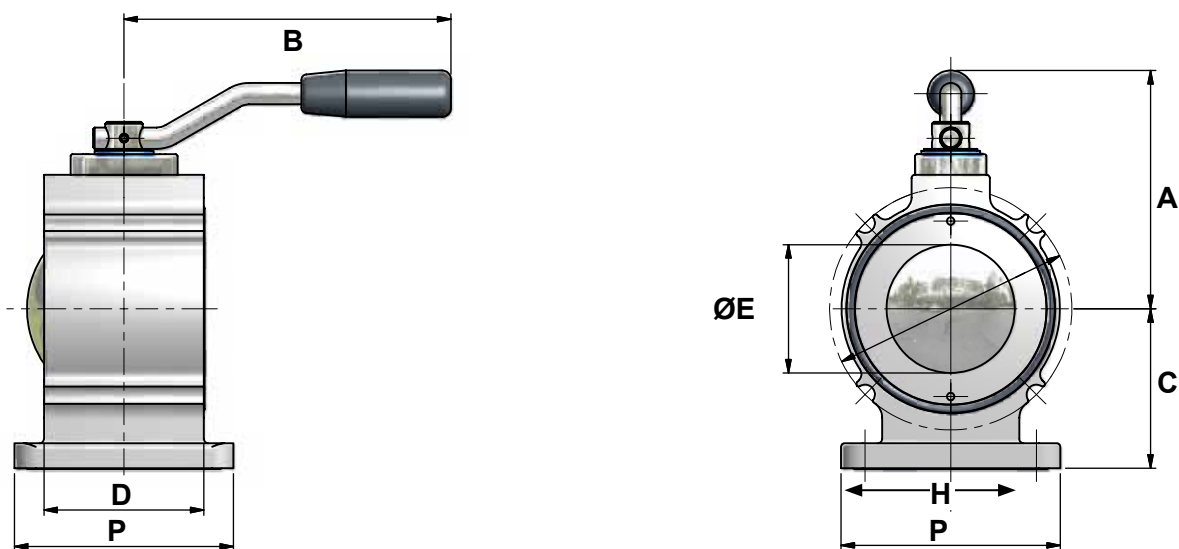

All measurements in mm/inch

Inch DN		A	B	C	D	ØE	ØG	H	P	Code No.	
<b>2" / DN 50</b>	mm	116	200	70	65	45	99	Ø99	4xØ8,4	92	<b>B200A1001C</b>
	inch	4.57	7.87	2.76	2.56	1.77	3.90	Ø 3.90	4xØ0.33	3.62	
<b>3" / DN 80</b>	mm	134	200	90	90	70	136	Ø136	4xØ10,5	123	<b>B400A1001C</b>
	inch	5.28	7.87	3.54	3.54	2.76	5.35	Ø 5.35	4xØ0.41	4.84	
<b>4" / DN 100</b>	mm	156	200	112	125	98	179	Ø179	4xØ10,5	166	<b>B500A1001C</b>
	inch	6.14	7.87	4.41	4.92	3.86	7.05	Ø 7.05	4xØ0.41	6.54	



## Ball Valves in Aluminium. Female BSP threaded Aluminium flange.

Flat sealing surface

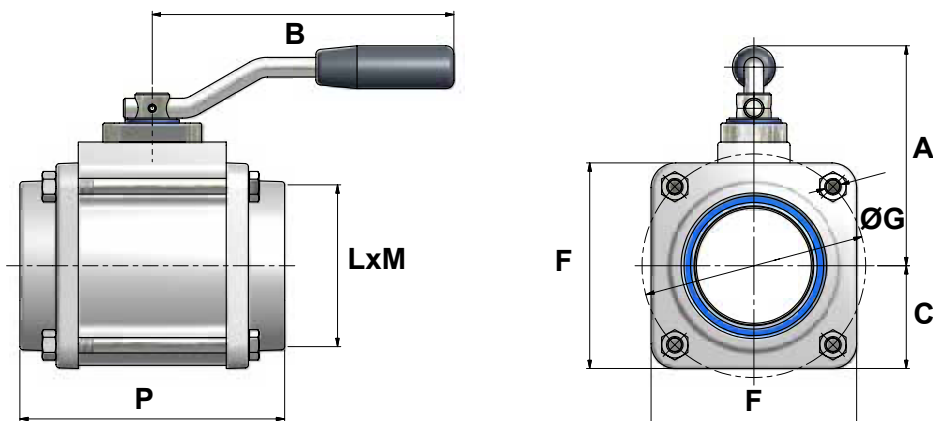

All measurements in mm/inch

Inch DN		A	B	C	F	ØG	L	M	P	Code No.
2" / DN 50	mm	116	200	50	93	99	2"BSP ISO228G2	20	114	<b>B210A1101</b>
	inch	4.57	7.87	1.97	3.66	3.90		0.79	4.49	
3" / DN 80	mm	134	200	66	125	136	3"BSP ISO228G3	22	161	<b>B414A1101</b>
	inch	5.28	7.87	2.60	4.92	5.35		0.87	6.34	
4" / DN 100	mm	156	200	86	165	179	4"BSP ISO228G4	24	185	<b>B516A1101</b>
	inch	6.14	7.87	3.39	6.60	7.05		0.95	7.28	

## 2-way Valves in Aluminium. Female BSP threaded Aluminium flange.

Flat sealing surface

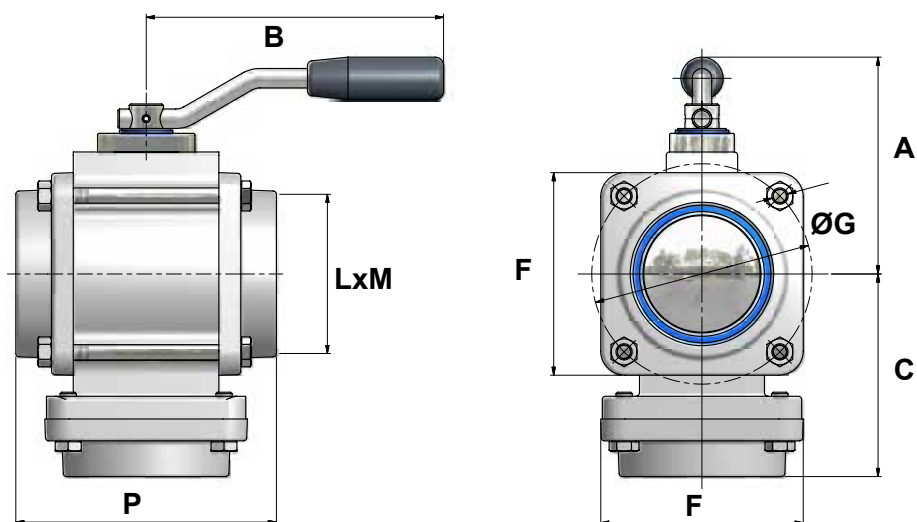

All measurements in mm/inch

Inch DN		A	B	C	F	ØG	L	M	P	Code No.
2" / DN 50	mm	116	200	100	93	99	2"BSP ISO228G2	20	114	<b>B210A1101C</b>
	inch	4.57	7.87	3.94	3.66	3.90		0.79	4.49	
3" / DN 80	mm	134	200	124	125	136	3"BSP ISO228G3	22	161	<b>B414A1101C</b>
	inch	5.28	7.87	4.88	4.92	5.35		0.87	6.34	
4" / DN 100	mm	156	200	150	165	179	4"BSP ISO228G4	24	185	<b>B516A1101C</b>
	inch	6.14	7.87	5.91	6.60	7.05		0.95	7.28	

## Ball Valves in Aluminium. Female BSP threaded Steel flange.

Flat sealing surface

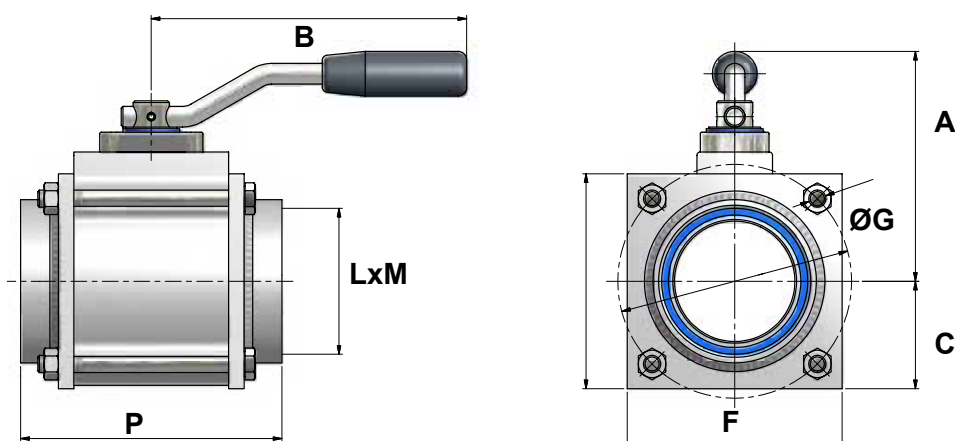

All measurements in mm/inch

Inch DN		A	B	C	F	ØG	L	M	P	Code No.
2" / DN 50	mm	116	200	47	93	99	2"BSP ISO228G2	20	114	B210A1301
	inch	4.57	7.87	1.85	3.66	3.90		0.79	4.49	
3" / DN 80	mm	134	200	63	125	136	3"BSP ISO228G3	22	161	B414A1301
	inch	5.28	7.87	2.48	4.92	5.35		0.87	6.34	
4" / DN 100	mm	156	200	83	165	179	4"BSP ISO228G4	24	185	B516A1301
	inch	6.14	7.87	3.27	6.50	7.05		0.95	7.28	

## 2-way Valves in Aluminium. Female BSP threaded Steel flange.

Flat sealing surface

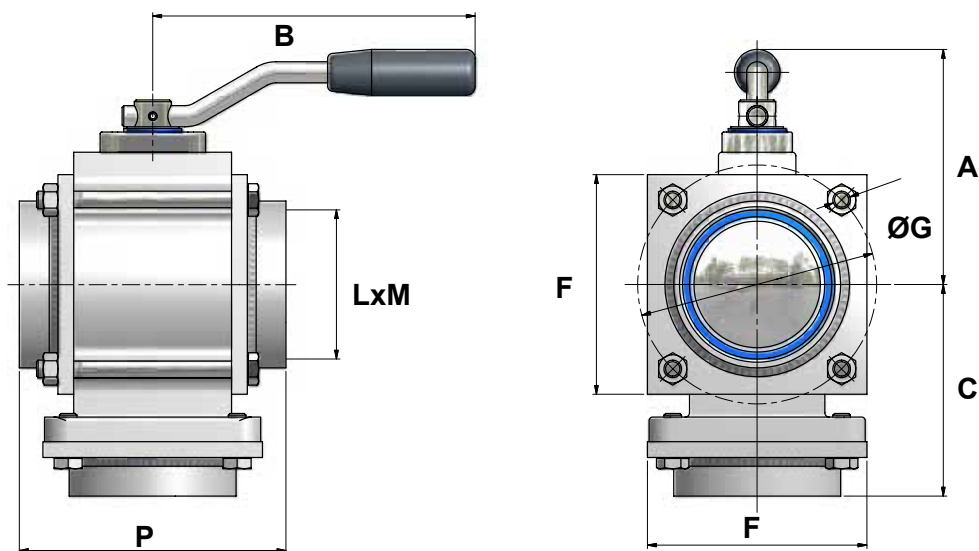

All measurements in mm/inch

Inch DN		A	B	C	F	ØG	L	M	P	Code No.
2" / DN 50	mm	116	200	97	93	99	2"BSP ISO228G2	20	114	B210A1301C
	inch	4.57	7.87	3.82	3.66	3.90		0.79	4.49	
3" / DN 80	mm	134	200	121	125	136	3"BSP ISO228G3	22	161	B414A1301C
	inch	5.28	7.87	4.76	4.92	5.35		0.87	6.34	
4" / DN 100	mm	156	200	147	165	179	4"BSP ISO228G4	24	185	B516A1301C
	inch	6.14	7.87	5.79	6.50	7.05		0.95	7.28	

## Ball Valves in Aluminium. Female NPT threaded Aluminium flange.

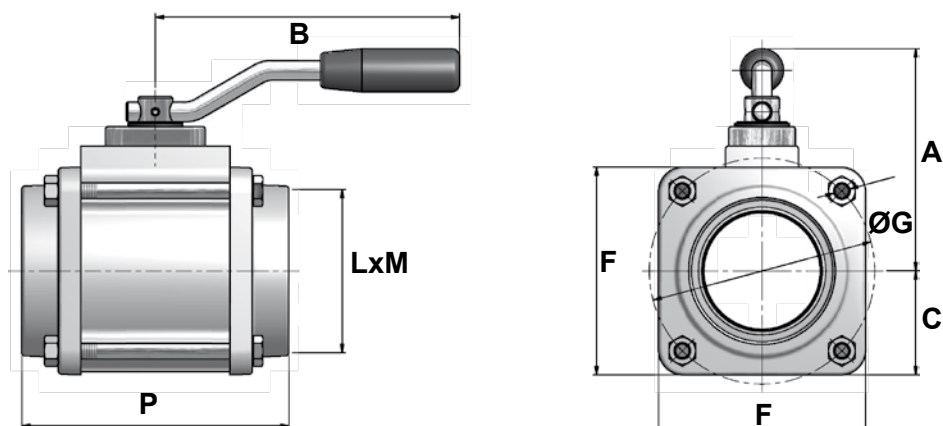

All measurements in mm/inch

Inch DN		A	B	C	F	ØG	L	M	P	Code No.
2" / DN 50	mm	116	200	47	93	99	2" NPT	21,5	134	B211A1101
	inch	4.57	7.87	1.85	3.66	3.90		0.85	5.28	
3" / DN 80	mm	134	200	63	125	136	3" NPT	32	181	B415A1101
	inch	5.28	7.87	2.48	4.92	5.35		1.26	7.13	
4" / DN 100	mm	156	200	83	165	179	4" NPT	34	208	B517A1101
	inch	6.14	7.87	3.27	6.50	7.05		1.34	8.19	

## 2-way Valves in Aluminium. Female NPT threaded Aluminium flange.

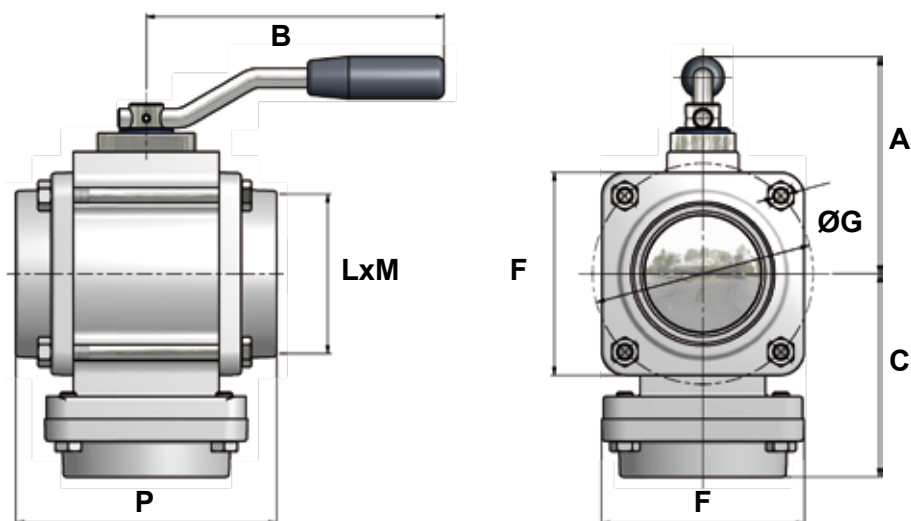

All measurements in mm/inch

Inch DN		A	B	C	F	ØG	L	M	P	Code No.
2" / DN 50	mm	116	200	105	93	99	2" NPT	21,5	134	B211A1101C
	inch	4.57	7.87	4.13	3.66	3.90		0.85	5.28	
3" / DN 80	mm	134	200	135	125	136	3" NPT	32	181	B415A1101C
	inch	5.28	7.87	5.31	4.92	5.35		1.26	7.13	
4" / DN 100	mm	156	200	153	165	179	4" NPT	34	208	B517A1101C
	inch	6.14	7.87	6.02	6.50	7.05		1.34	8.19	

## Ball Valves in Aluminium. Male BSP threaded Aluminium flange

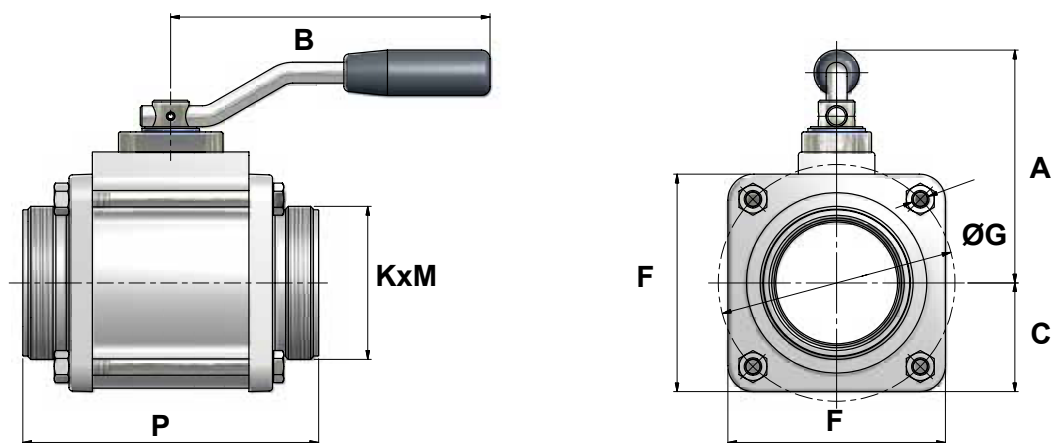

All measurements in mm/inch

Inch DN		A	B	C	F	ØG	K	M	P	Code No.
<b>2" / DN 50</b>	mm	116	200	47	93	99	2"BSP ISO228G2	31	141	<b>B278A1101</b>
	inch	4.57	7.87	1.85	3.66	3.90		1.22	4.68	
<b>3" / DN 80</b>	mm	134	200	63	125	136	3"BSP ISO228G3	29	166	<b>B482A1101</b>
	inch	5.28	7.87	2.48	4.92	5.35		1.14	5.98	
<b>4" / DN 100</b>	mm	156	200	83	165	179	4"BSP ISO228G4	31	209	<b>B584A1101</b>
	inch	6.14	7.87	3.27	6.50	7.05		1.22	8.23	

## 2-way Valves in Aluminium. Male BSP threaded Aluminium flange

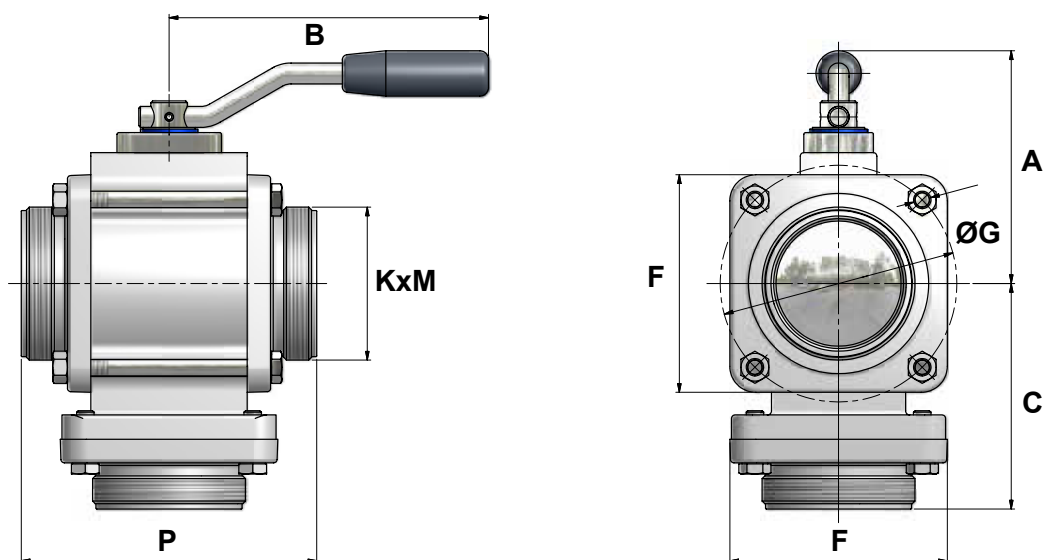

All measurements in mm/inch

Inch DN		A	B	C	F	ØG	K	M	P	Code No.
<b>2" / DN 50</b>	mm	116	200	108	93	99	2"BSP ISO228G2	31	141	<b>B278A1101C</b>
	inch	4.57	7.87	4.25	3.66	3.90		1.22	4.68	
<b>3" / DN 80</b>	mm	134	200	128	125	136	3"BSP ISO228G3	29	166	<b>B482A1101C</b>
	inch	5.28	7.87	5.04	4.92	5.35		1.14	5.98	
<b>4" / DN 100</b>	mm	156	200	154	165	179	4"BSP ISO228G4	31	209	<b>B584A1101C</b>
	inch	6.14	7.87	6.06	6.50	7.05		1.22	8.23	



## Ball Valves in Aluminium. Male BSP threaded Steel flange

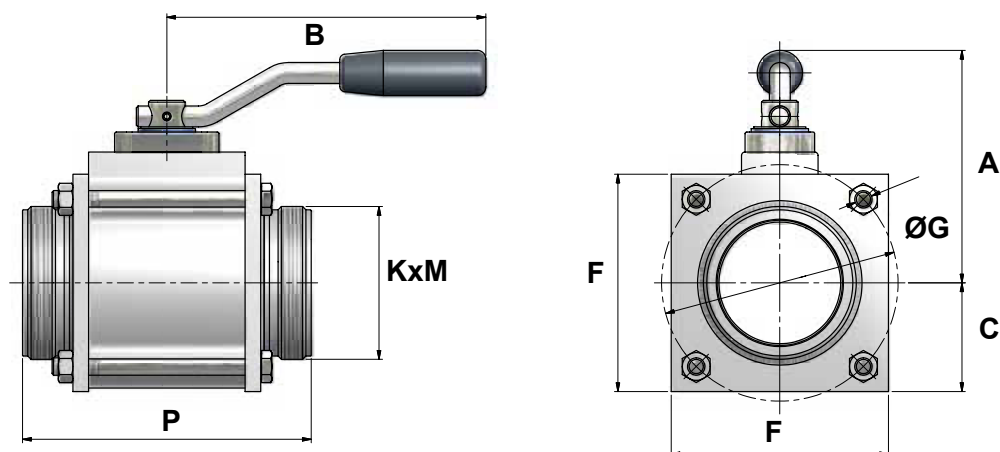

All measurements in mm/inch

Inch DN		A	B	C	F	ØG	K	M	P	Code No.
<b>2" / DN 50</b>	mm	116	200	47	93	99	2"BSP ISO228G2	31	141	<b>B278A1301</b>
	inch	4.57	7.87	1.85	3.66	3.90		1.22	4.68	
<b>3" / DN 80</b>	mm	134	200	63	125	136	3"BSP ISO228G3	29	166	<b>B482A1301</b>
	inch	5.28	7.87	2.48	4.92	5.35		1.14	5.98	
<b>4" / DN 100</b>	mm	156	200	83	165	179	4"BSP ISO228G4	31	209	<b>B584A1301</b>
	inch	6.14	7.87	3.27	6.50	7.05		1.22	8.23	

## 2-way Valves in Aluminium. Male BSP threaded Steel flange

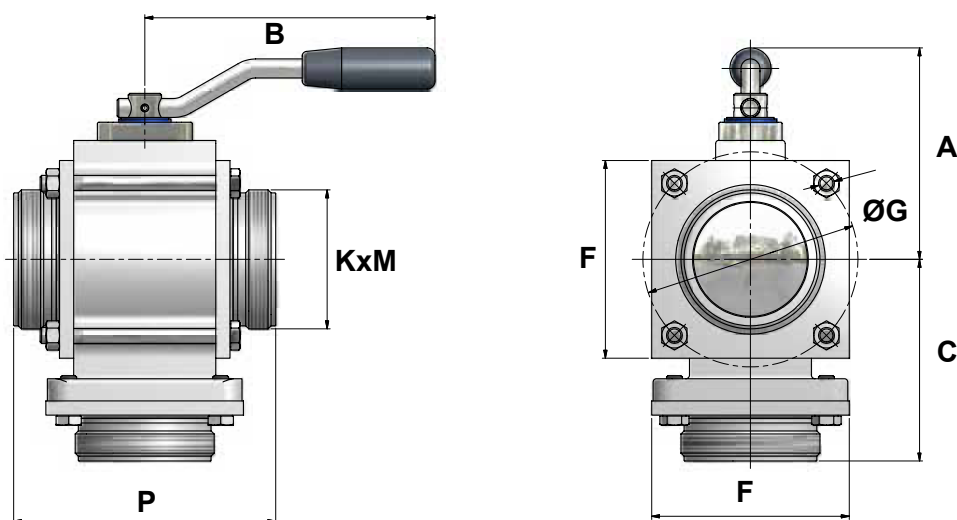

All measurements in mm/inch

Inch DN		A	B	C	F	ØG	K	M	P	Code No.
<b>2" / DN 50</b>	mm	116	200	108	93	99	2"BSP ISO228G2	31	141	<b>B278A1301C</b>
	inch	4.57	7.87	4.25	3.66	3.90		1.22	4.68	
<b>3" / DN 80</b>	mm	134	200	128	125	136	3"BSP ISO228G3	29	166	<b>B482A1301C</b>
	inch	5.28	7.87	5.04	4.92	5.35		1.14	5.98	
<b>4" / DN 100</b>	mm	156	200	154	165	179	4"BSP ISO228G4	31	209	<b>B584A1301C</b>
	inch	6.14	7.87	6.06	6.50	7.05		1.22	8.23	

## Ball Valves in Aluminium. Welding Steel flange 60 mm/89mm/114mm

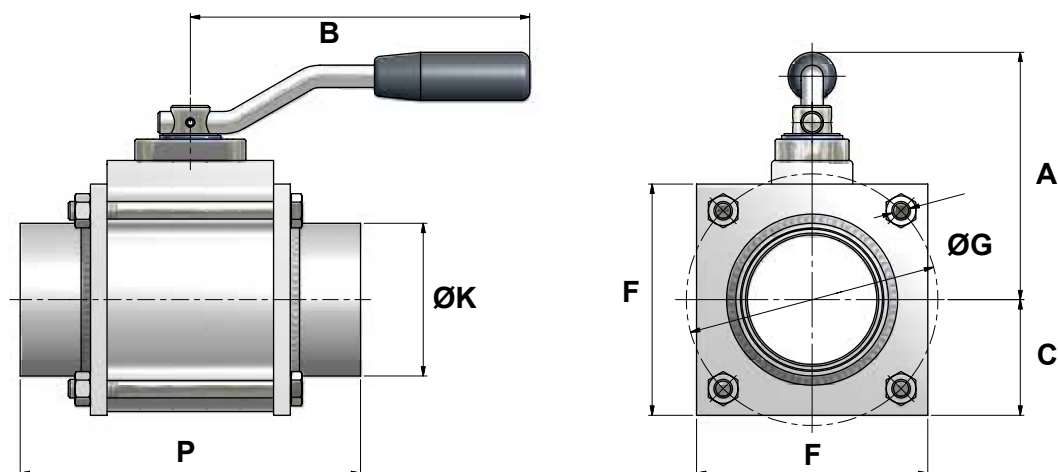

All measurements in mm/inch

Inch DN		A	B	C	F	ØG	ØK	P	Code No.
2" / DN 50	mm	116	200	47	93	99	W60	134	<b>B290A1301</b>
	inch	4.57	7.87	1.85	3.66	3.90	W2.36	5.28	
3" / DN 80	mm	134	200	63	125	136	W89	149	<b>B493A1301</b>
	inch	5.28	7.87	2.48	4.92	5.35	W3.50	5.87	
4" / DN 100	mm	156	200	83	165	179	W114	223	<b>B597A1301</b>
	inch	6.14	7.87	3.27	6.50	7.05	W4.49	8.78	

## 2-way Valves in Aluminium. Welding Steel flange 60 mm/89mm/114mm

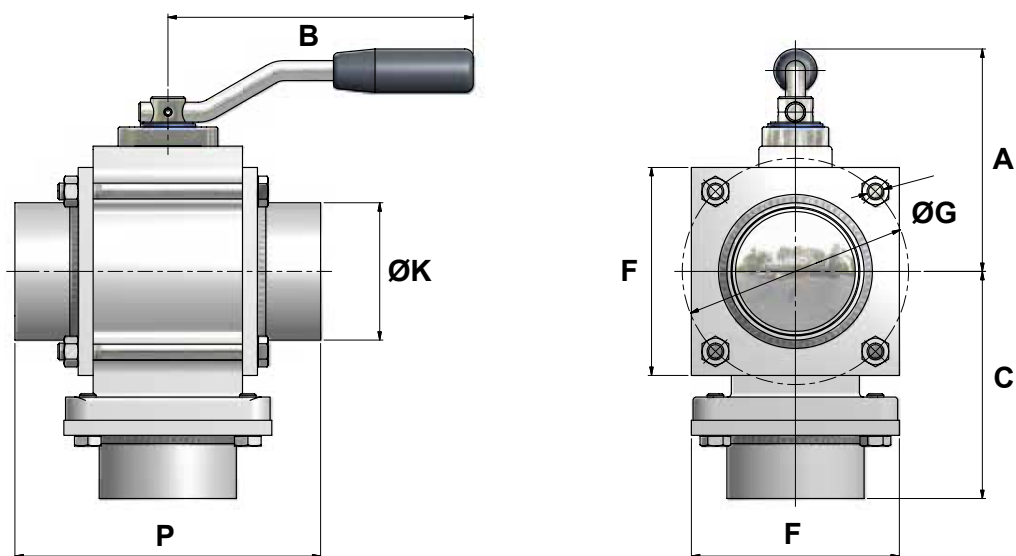

All measurements in mm/inch

Inch DN		A	B	C	F	ØG	ØK	P	Code No.
2" / DN 50	mm	116	200	105	93	99	W60	134	<b>B290A1301C</b>
	inch	4.57	7.87	4.13	3.66	3.90	W2.36	5.28	
3" / DN 80	mm	134	200	120	125	136	W89	149	<b>B493A1301C</b>
	inch	5.28	7.87	4.72	4.92	5.35	W3.50	5.87	
4" / DN 100	mm	156	200	161	165	179	W114	223	<b>B597A1301C</b>
	inch	6.14	7.87	6.34	6.50	7.05	W4.49	8.78	

## Ball Valves in Aluminium. Welding Stainless Steel flange 60 mm/89mm

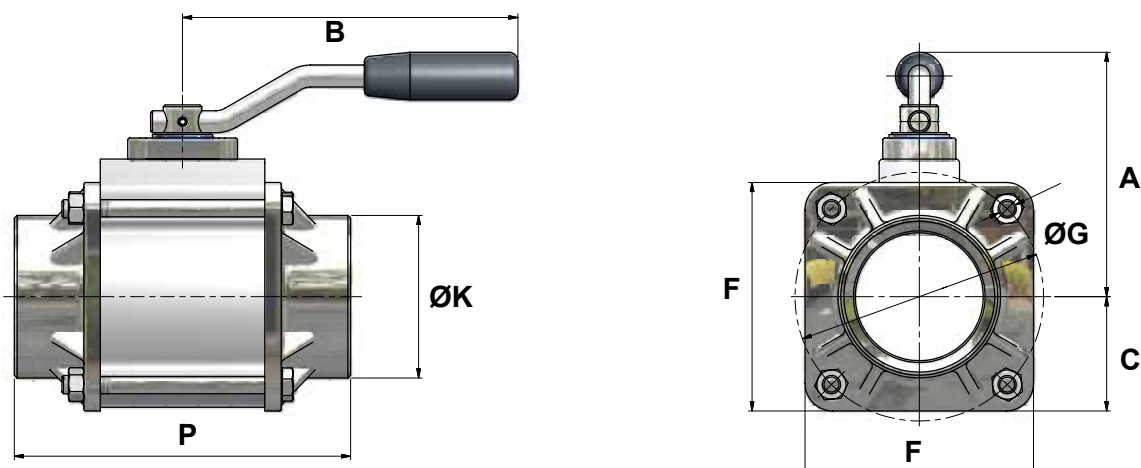

All measurements in mm/inch

Inch DN		A	B	C	F	ØG	ØK	P	Code No.
<b>2" / DN 50</b>	mm	116	200	47	93	99	W60	134	<b>B290A1401</b>
	inch	4.57	7.87	1.85	3.66	3.90	W2.36	5.28	
<b>3" / DN 80</b>	mm	134	200	63	125	136	W89	149	<b>B493A1401</b>
	inch	5.28	7.87	2.48	4.92	5.35	W3.50	5.87	
<b>4" / DN 100</b>	mm	156	200	83	165	179	W114	223	<b>B597A1401</b>
	inch	6.14	7.87	3.27	6.50	7.05	W4.49	8.78	

## 2-way Valves in Aluminium. Welding Stainless Steel flange 60 mm/ 89mm/114 mm

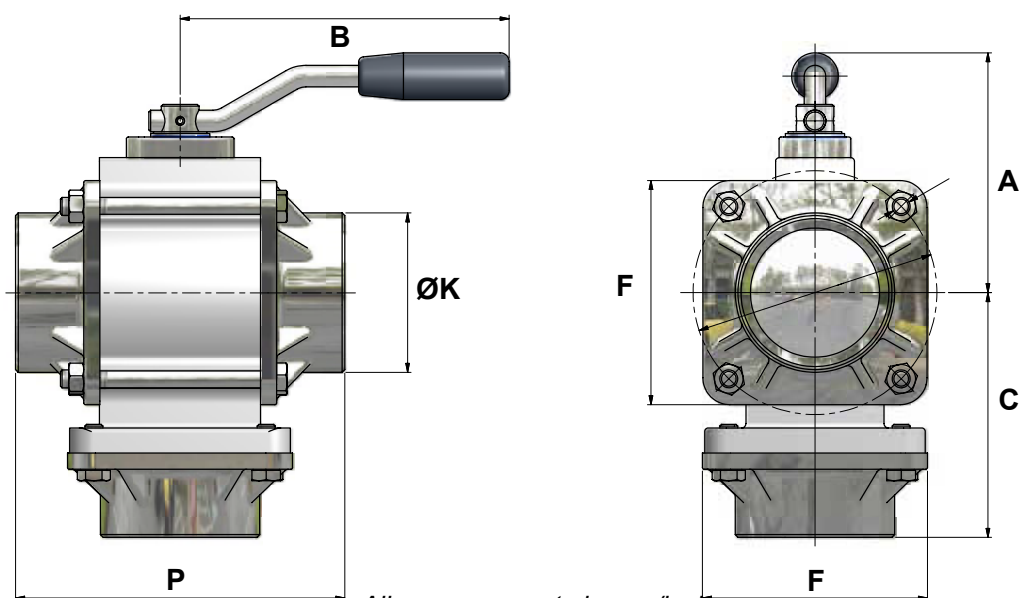

All measurements in mm/inch

Inch DN		A	B	C	F	ØG	ØK	P	Code No.
<b>2" / DN 50</b>	mm	116	200	105	93	99	W60	134	<b>B290A1401C</b>
	inch	4.57	7.87	4.13	3.66	3.90	W2.36	5.28	
<b>3" / DN 80</b>	mm	134	200	120	125	136	W89	149	<b>B493A1401C</b>
	inch	5.28	7.87	4.72	4.92	5.35	W3.50	5.87	
<b>4" / DN 100</b>	mm	156	200	161	165	179	W114	223	<b>B597A1401C</b>
	inch	6.14	7.87	6.34	6.50	7.05	W4.49	8.78	

## Ball Valves in Aluminium. Flat welding Aluminium flange 57mm/76 mm/89mm/108mm

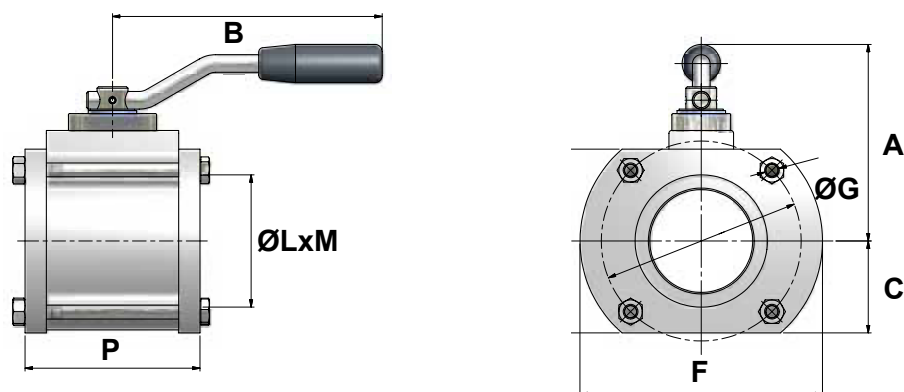

All measurements in mm/inch

Inch	DN		A	B	C	F	ØG	ØL	M	P	Code No.
2"	DN 50	mm	116	200	47	93	99	W57	2	83	B289A1101
		inch	4.57	7.87	1.85	3.66	3.90	W2.24	0.08	3.27	
3"	DN 80	mm	134	200	63	125	136	W76	2	112	B492A1101
		inch	5.28	7.87	2.48	4.92	5.35	W2.99	0.08	4.41	
3"	DN 80	mm	134	200	63	125	136	W89	2	112	B493A1101
		inch	5.28	7.87	2.48	4.92	5.35	W3.50	0.08	4.41	
4"	DN 100	mm	156	200	83	165	179	W108	2	153	B596A1101
		inch	6.14	7.87	3.27	6.50	7.05	W4.25	0.08	6.02	

## 2-way Valves in Aluminium. Flat welding Aluminium flange 57mm/76 mm/89mm/108mm

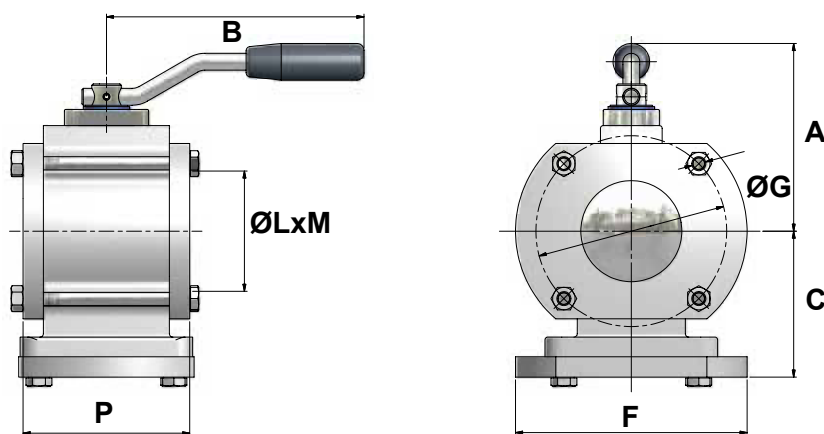

All measurements in mm/inch

Inch	DN		A	B	C	F	ØG	ØL	M	P	Code No.
2"	DN 50	mm	116	200	88	93	99	W57	2	83	B289A1101C
		inch	4.57	7.87	3.46	3.66	3.90	W2.24	0.08	3.27	
3"	DN 80	mm	134	200	112	125	136	W76	2	112	B492A1101C
		inch	5.28	7.87	4.41	4.92	5.35	W2.99	0.08	4.41	
3"	DN 80	mm	134	200	112	125	136	W89	2	112	B493A1101C
		inch	5.28	7.87	4.41	4.92	5.35	W3.50	0.08	4.41	
4"	DN 100	mm	156	200	140	165	179	W108	2	153	B596A1101C
		inch	6.14	7.87	5.51	6.50	7.05	W4.25	0.08	6.02	



## Ball Valves in Aluminium. Welding Steel flange 76 mm/102mm

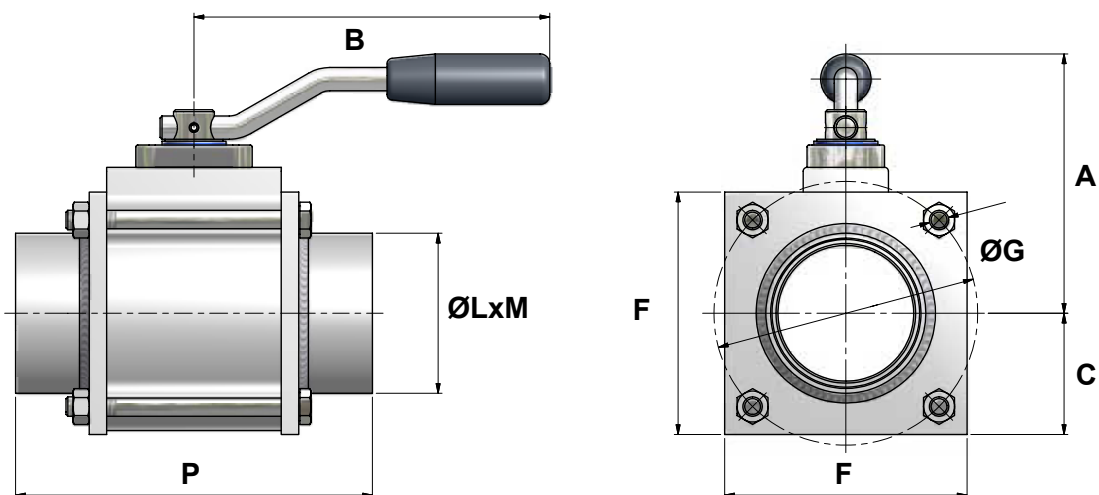

All measurements in mm/inch

Inch DN		A	B	C	F	ØG	ØL	M	P	Code No.
3" / DN 80	mm	134	200	63	125	136	W76	4	148	B492A1301
	inch	5.28	7.87	2.48	4.92	5.35	W2.99	0.16	5.83	
4" / DN 100	mm	156	200	83	165	179	W102	8	223	B595A1301
	inch	6.14	7.87	3.27	6.50	7.05	W4.02	0.31	8.78	

## 2-way Valves in Aluminium. Welding Steel flange 76 mm/102mm/

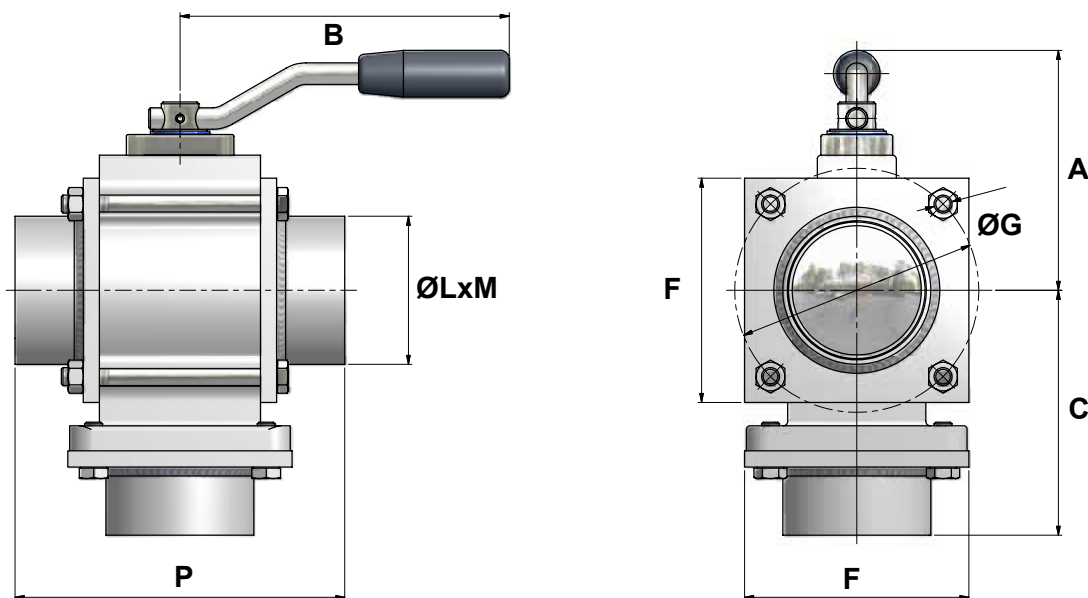

All measurements in mm/inch

Inch DN		A	B	C	F	ØG	ØL	M	P	Code No.
3" / DN 80	mm	134	200	120	125	136	W76	4	148	B492A1301C
	inch	5.28	7.87	4.72	4.92	5.35	W2.99	0.16	5.83	
4" / DN 100	mm	156	200	161	165	179	W102	8	223	B595A1301C
	inch	6.14	7.87	6.34	6.50	7.05	W4.02	0.31	8.78	

## Ball Valves in Aluminium with TW flange in Aluminium

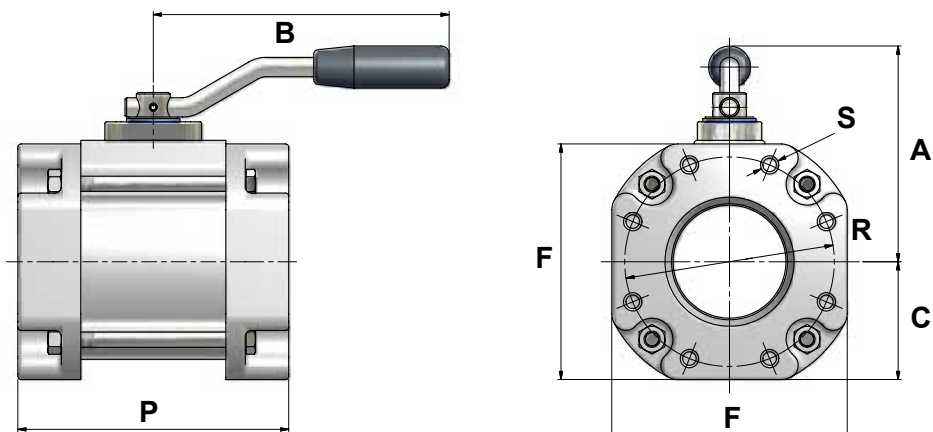

All measurements in mm/inch

Inch	DN		A	B	C	F	P	R	S	Code No.
3"	DN 50	mm	116	200	73	146	142	TW1	M10	B487A1101
		inch	4.57	7.87	2.87	5.75	5.59			
3"	DN 80	mm	134	200	73	146	168	TW1	M10	B465A1101
		inch	5.28	7.87	2.87	5.75	6.61			
4"	DN 100	mm	156	200	83	165	180	TW3	M12	B566A1101
		inch	6.14	7.87	3.27	6.50	7.09			

## 2-way Valves in Aluminium with TW flange in Aluminium

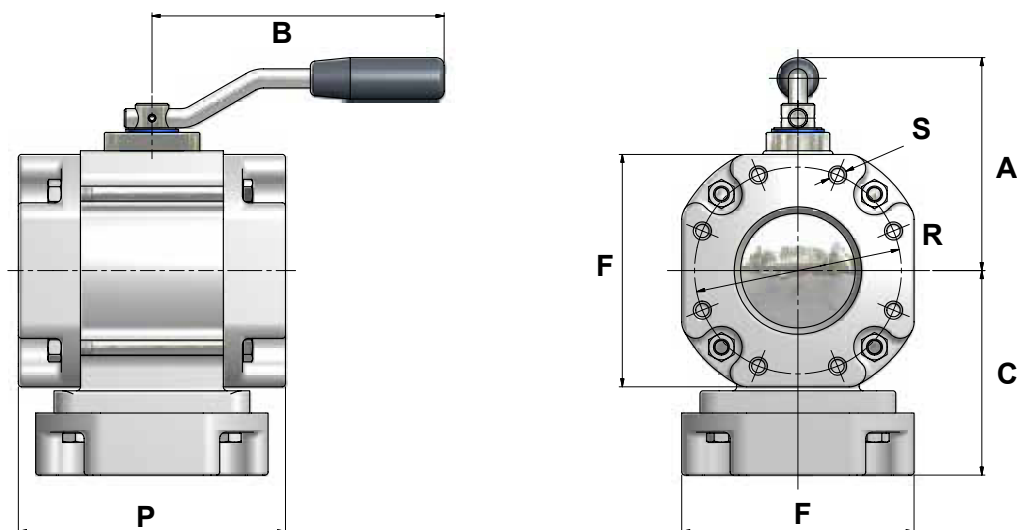

All measurements in mm/inch

Inch	DN		A	B	C	F	P	R	S	Code No.
3"	DN 50	mm	116	200	116	146	142	TW1	M10	B487A1101C
		inch	4.57	7.87	4.57	5.75	5.59			
3"	DN 80	mm	134	200	129	146	168	TW1	M10	B465A1101C
		inch	5.28	7.87	5.08	5.75	6.61			
4"	DN 100	mm	156	200	140	165	180	TW3	M12	B566A1101C
		inch	6.14	7.87	5.51	6.50	7.09			

## 4" Ball Valves with Aluminium flange Victaulic ANSI AWWA C-606

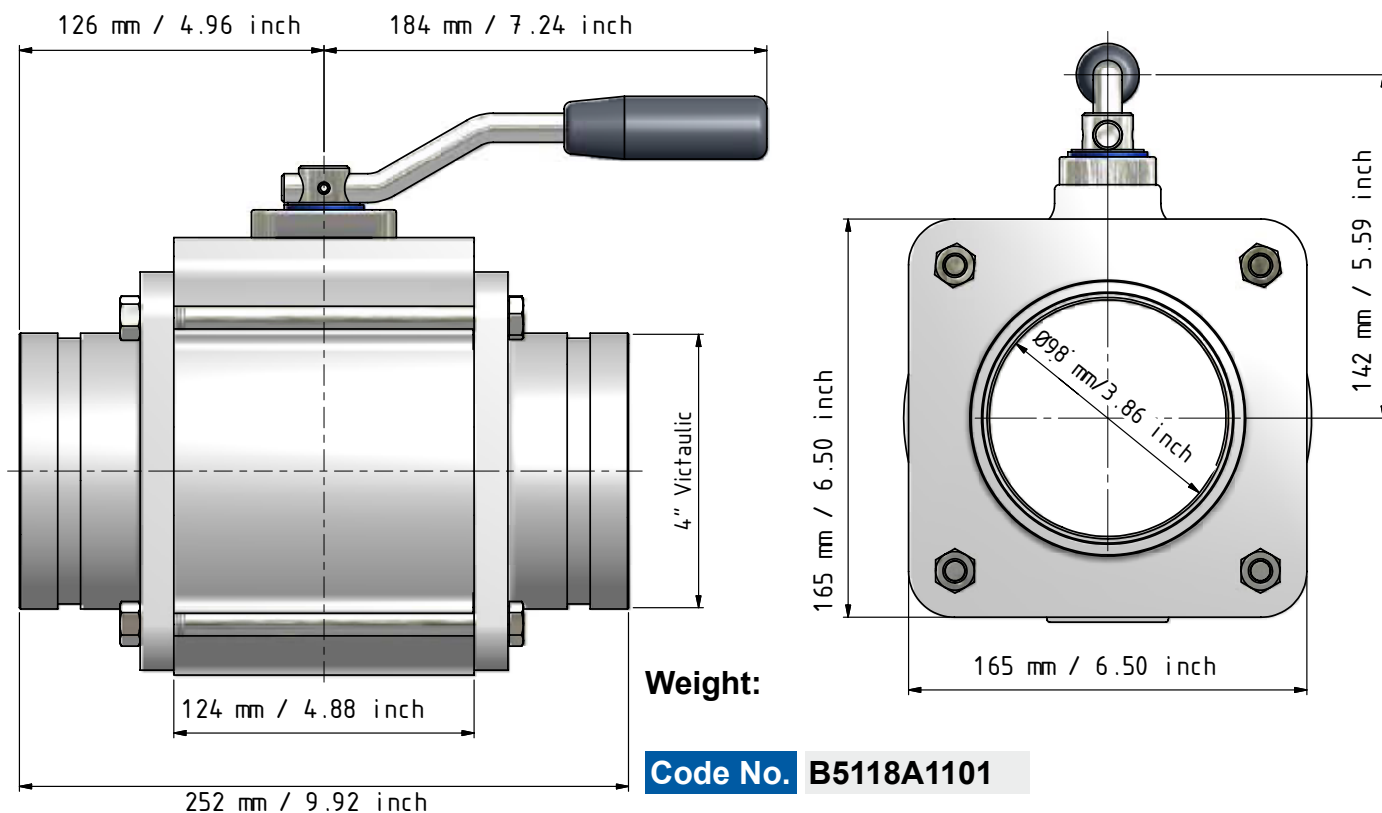

All measurements in mm/inch

## 4" Ball Valves with Stainless steel flange Victaulic ANSI AWWA C-606

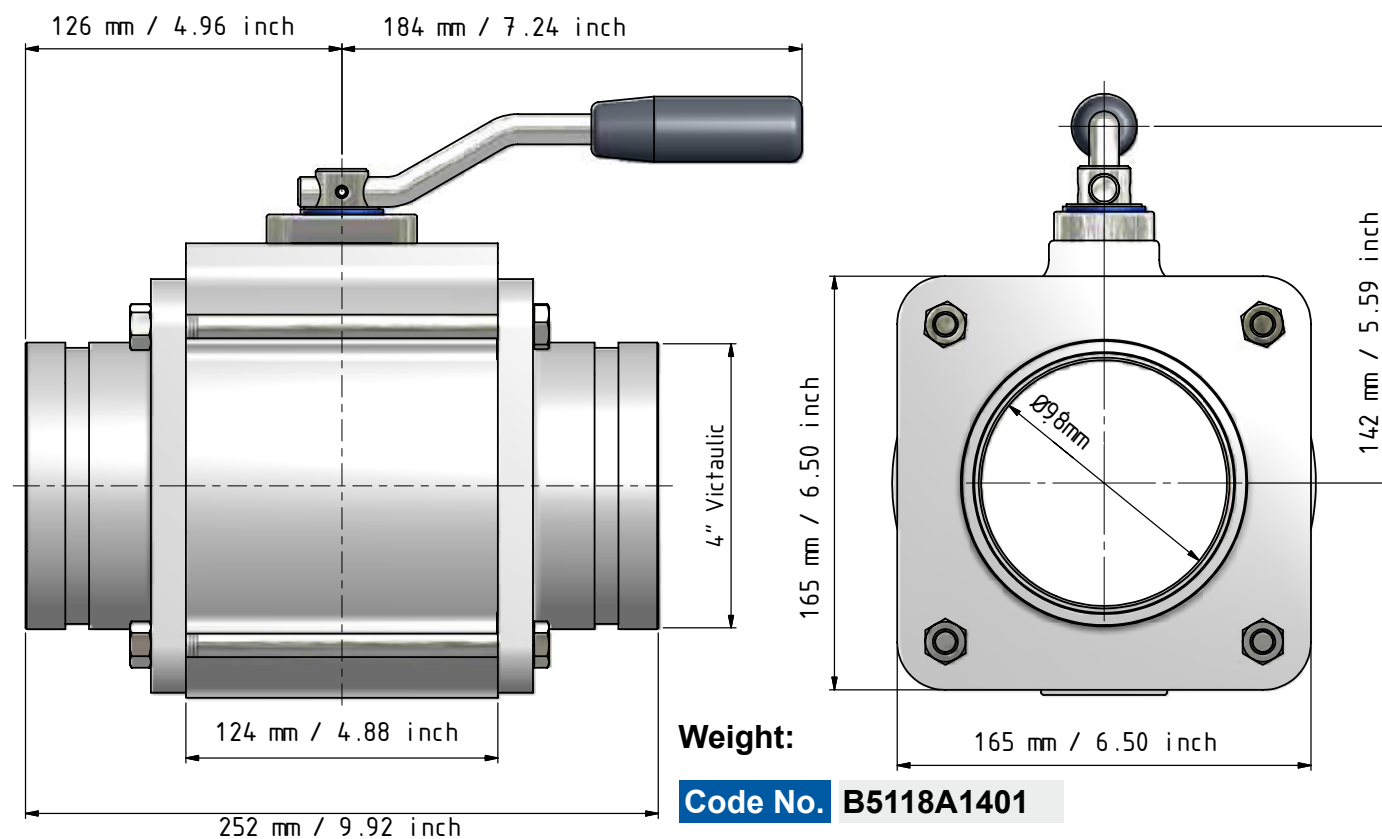

All measurements in mm/inch

### 3" Ball Valves with Aluminium flange DN 80 PN 10/16

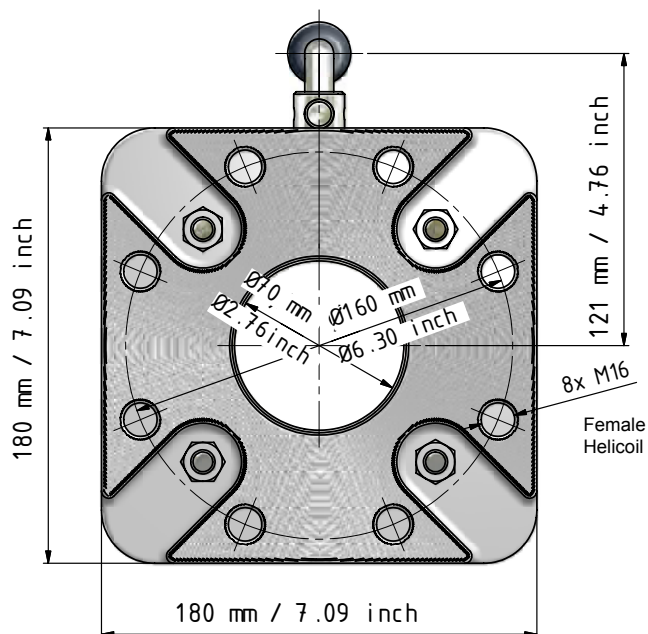
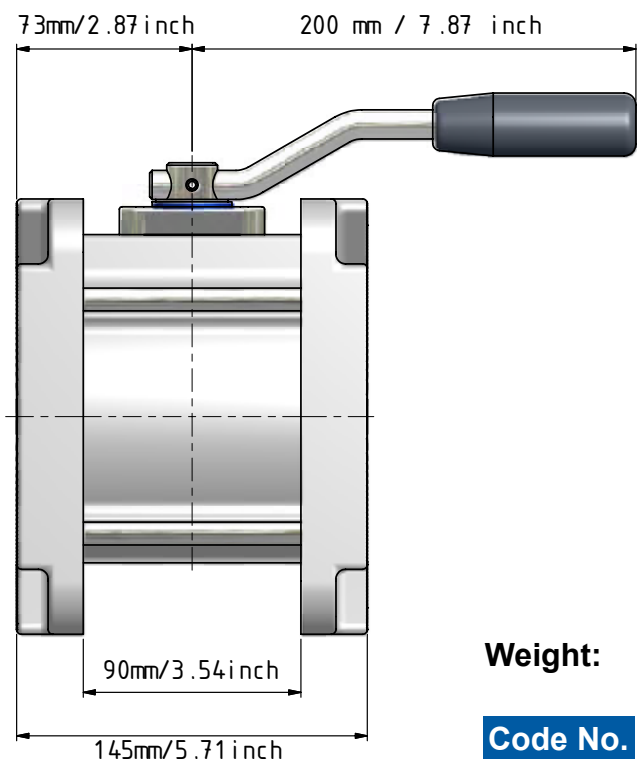

**Weight:**

**Code No. B436A1101**

All measurements in mm/inch

### 4" Ball Valves with Aluminium flange DN 100 PN 10/16

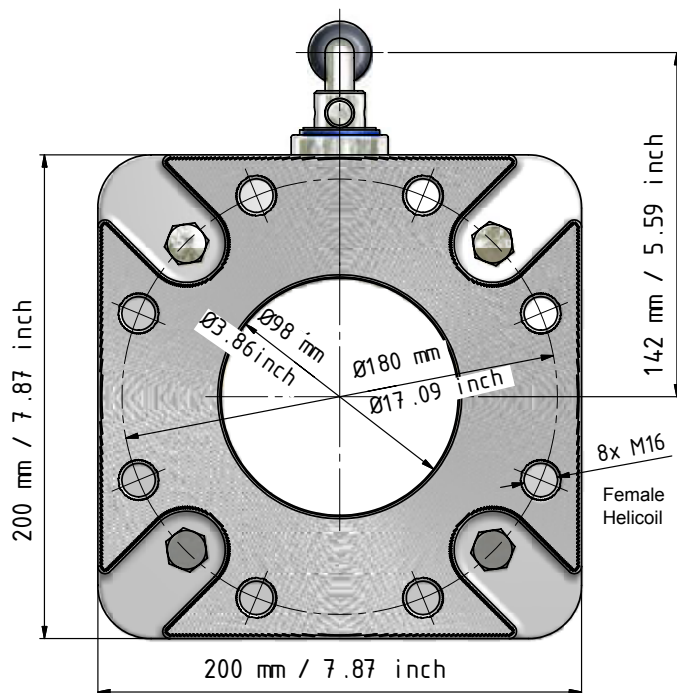
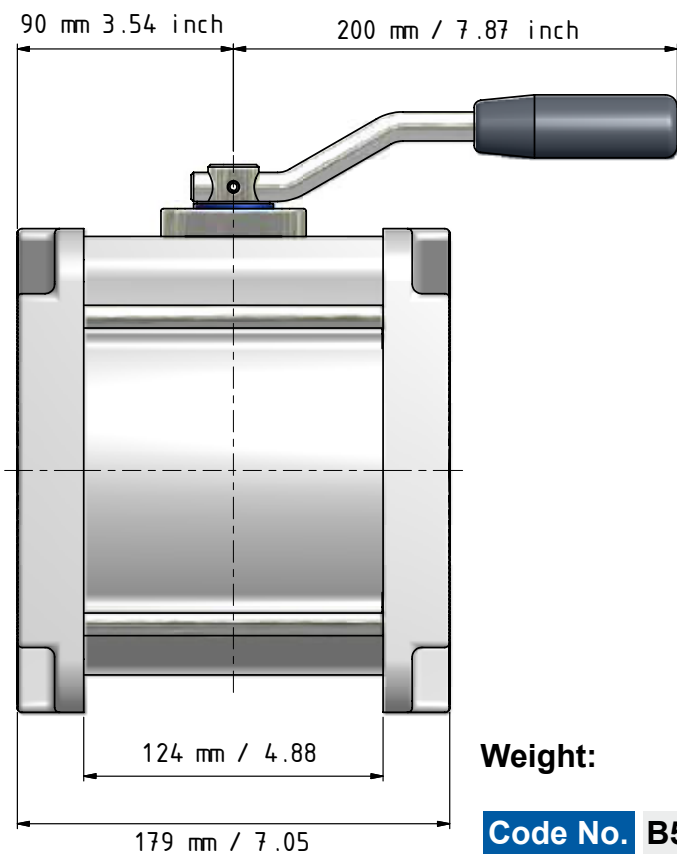

**Weight:**

**Code No. B539A1101**

All measurements in mm/inch



**2" Ball Valves with DN 50 TW1 flange in Aluminium - Special compact**

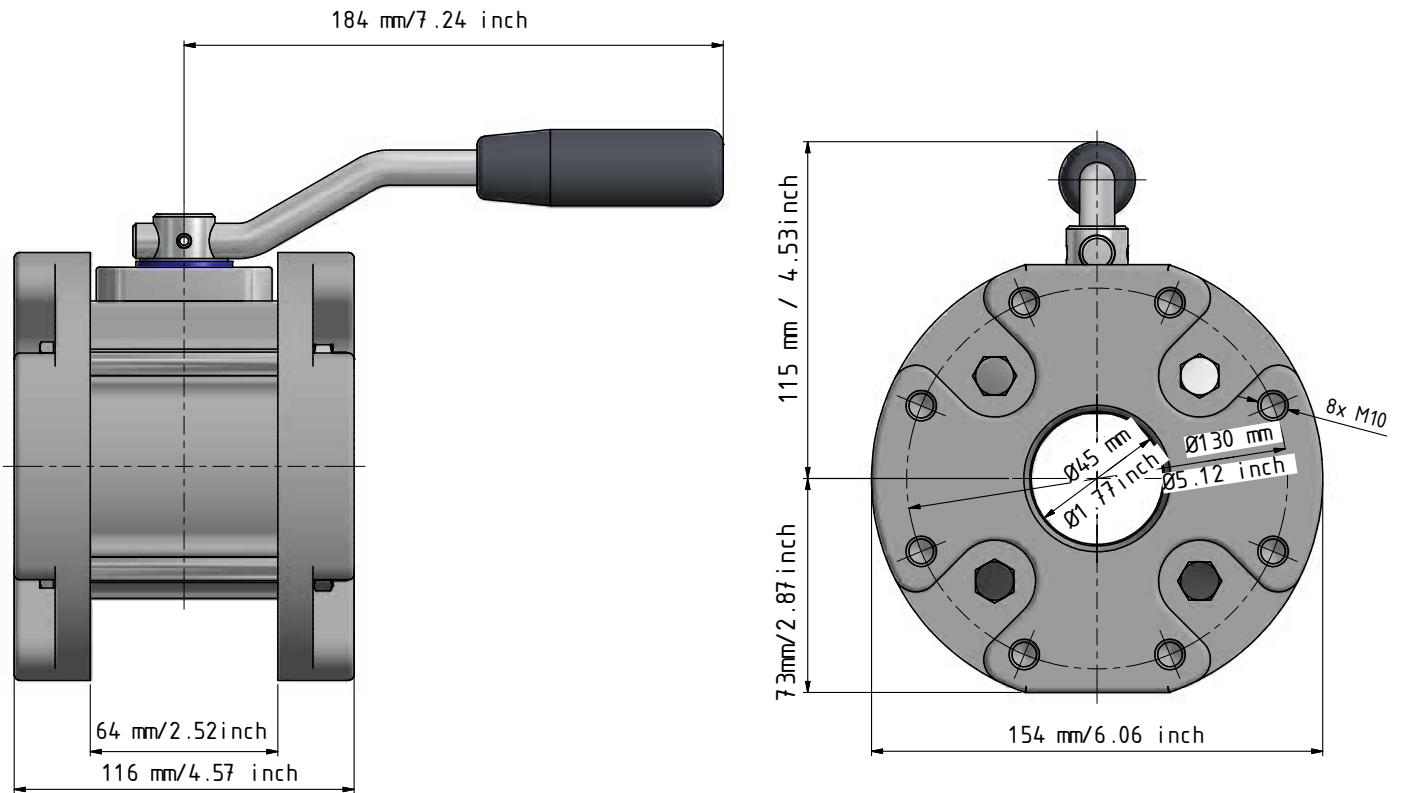

**Special compact version, built in measurement not according to TW standard.**

**Code No. B287A1101**

*All measurements in mm/inch*

## Ball Valves in Aluminium with pneumatic actuator double acting

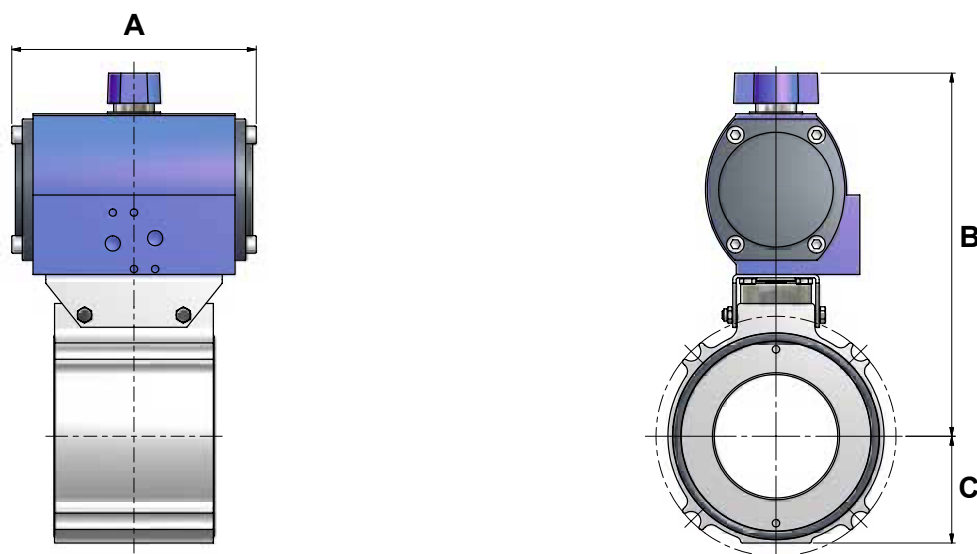

ATEX approved



All measurements in mm/inch

Inch DN	A		B		C		Code No.
	mm	inch	mm	inch	mm	inch	
2" / DN 50	140	5.51	190	7.48	45	1.77	B200A1001-DA
3" / DN 80	140	5.51	206	8.11	61	2.40	B400A1001-DA
4" / DN 100	160	6.30	250	9.84	85	3.35	B500A1001-DA

## 2-way Valves in Aluminium with pneumatic actuator double acting

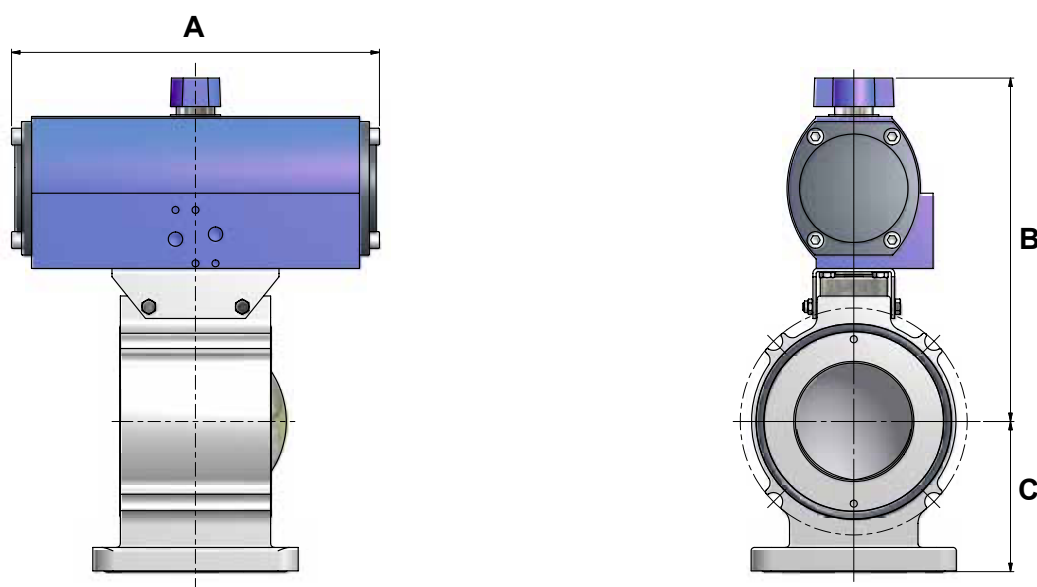

ATEX approved



All measurements in mm/inch

Inch DN	A		B		C		Code No.
	mm	inch	mm	inch	mm	inch	
2" / DN 50	220	8.66	190	7.48	70	2.76	B200A1001C-DA
3" / DN 80	220	8.66	206	8.11	90	3.54	B400A1001C-DA
4" / DN 100	245	9.65	250	9.84	112	4.41	B500A1001C-DA

## Ball Valves in Aluminium with pneumatic actuator springreturn

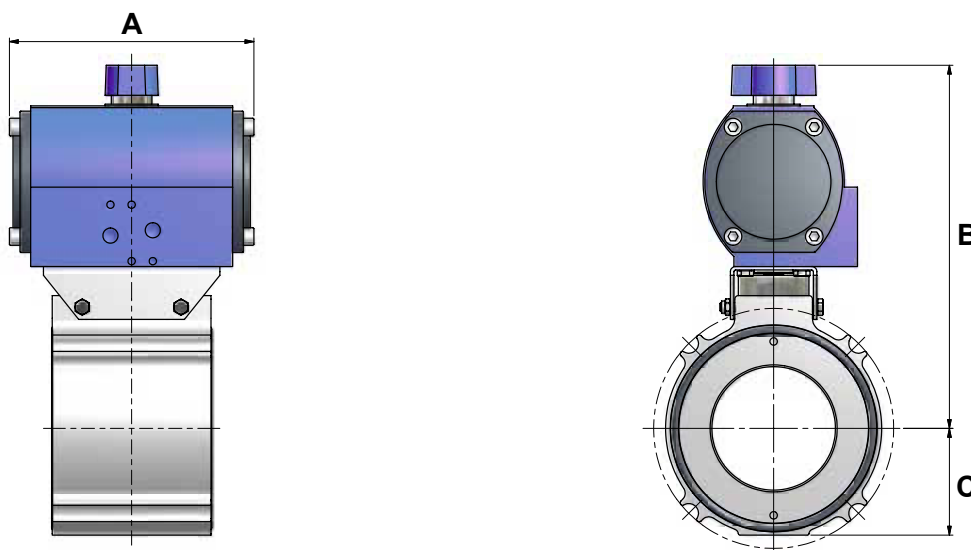

ATEX approved



All measurements in mm/inch

Inch DN	A		B		C		Code No.
	mm	inch	mm	inch	mm	inch	
2" / DN 50	140	5.51	190	7.48	70	2.76	200A1001-SR
3" / DN 80	140	5.51	206	8.11	90	3.54	B400A1001-SR
4" / DN 100	160	6.30	250	9.84	112	4.41	B500A1001-SR

## Ball Valves - Special on request

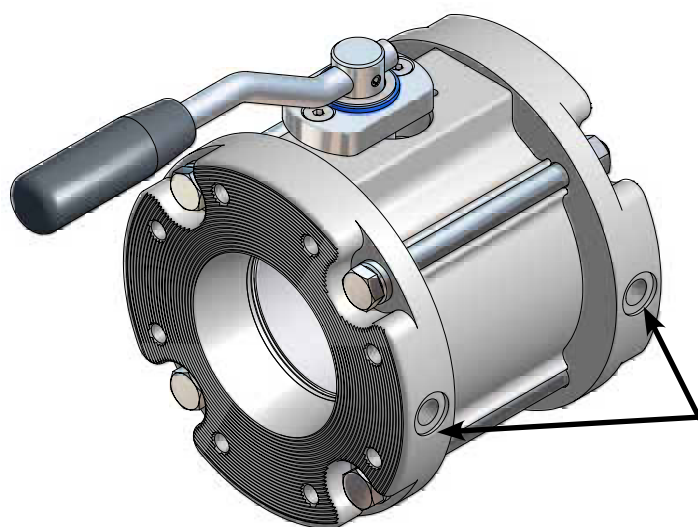

### 3" Ball Valve

**Connection:**

Aluminium flanges TW1 (both sides).

**Extra:**

Female BSP 1/4" thread for draining or sensors (pressure, temperature)

**Ball Valves - Special on request**

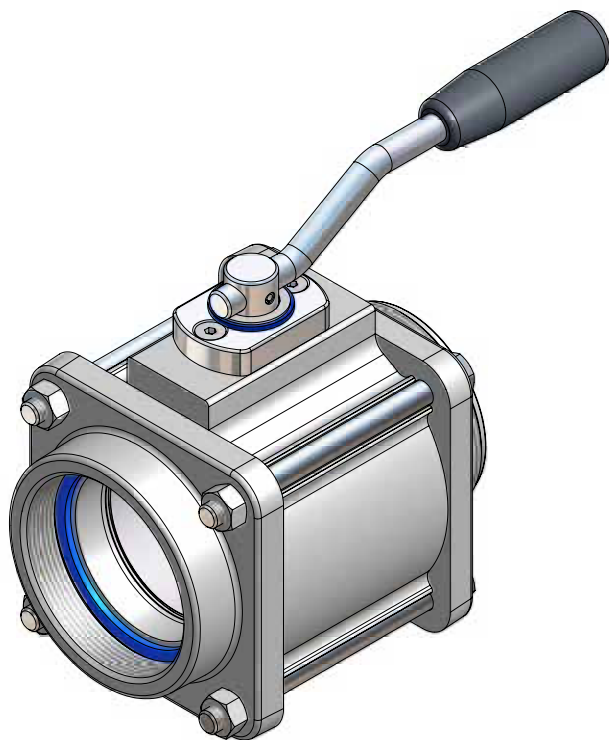

**3" Ball Valve with Aluminium female flanges**

**Connection:**  
One side female 3" BSP thread and other side male 3" BSP thread.

**Code No.** B400A1001 + 1322 -1B + 1329-1B

**3" Ball Valve with Aluminium flanges**

**Connection:**  
One side Aluminium welding flange Ø89 mm and other side Aluminium flange TW1

**Code No.** B400A1001 + 1340 -1 + 1327-1

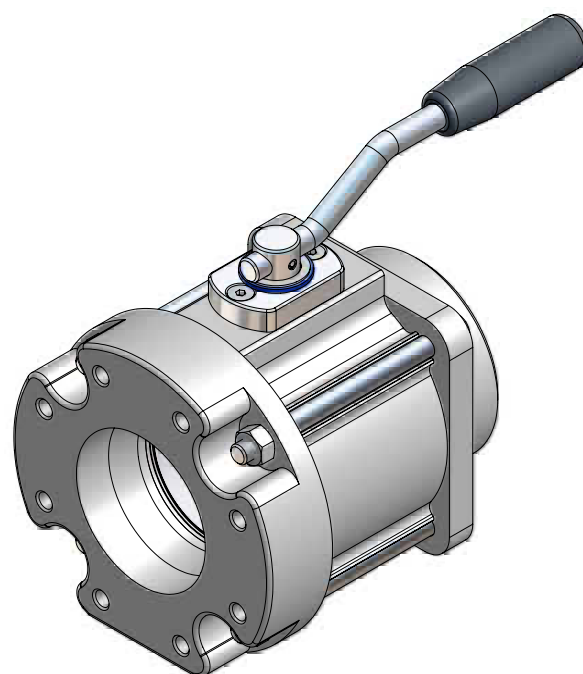

**3" Ball Valve with Aluminium flanges**

**Connection:**  
One side 3" BSP male and other side Aluminium flange TW1

**Code No.** B400A1001 + 1329 -1B + 1327-1

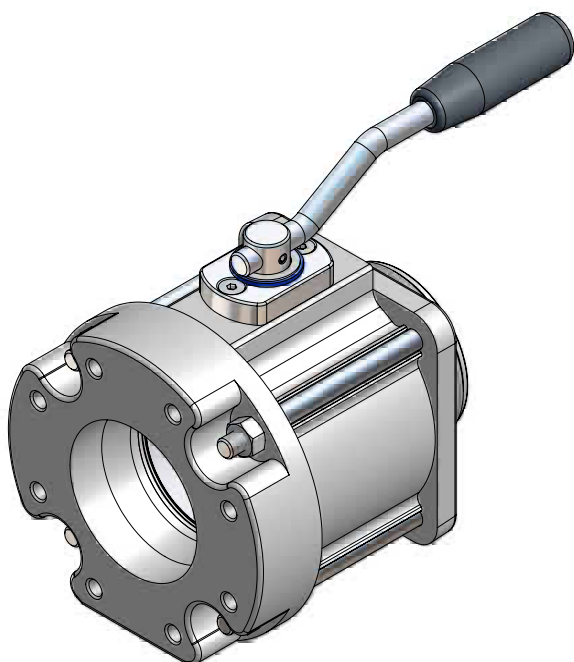



**Ball Valves - Special on request**



**4" Ball Valve with Aluminium flanges**

**Connection:**  
One side 4" BSP male threads and other side 4" BSP female threads flanges



**4" Ball Valve**

- Option:**
- Long handle
  - Steel Zink plated, or Stainless steel
  - Body anodised, black
  - Not electrical conductivity



**4" Ball Valve**

- Option:**
- Painted according to RAL (Color standard for Military)
  - Bolts and nuts in Stainless steel.

Examples of Military RAL colours	
	<b>RAL 6014</b> Yellow Olive - Dutch Army
	<b>RAL 6031</b> Bronze Green - Dutch, Germany, Denmark, Spain, Italy and Sweden.
	<b>RAL 8027</b> Leather Brown - Germany
	<b>RAL 9021</b> Tar Black - Germany
<b>Other colours on request</b>	

Specifications subject to change without notice - Copyright Mann Teknik AB

**2" DN 50 2" BSP Female thread flange, Aluminium**

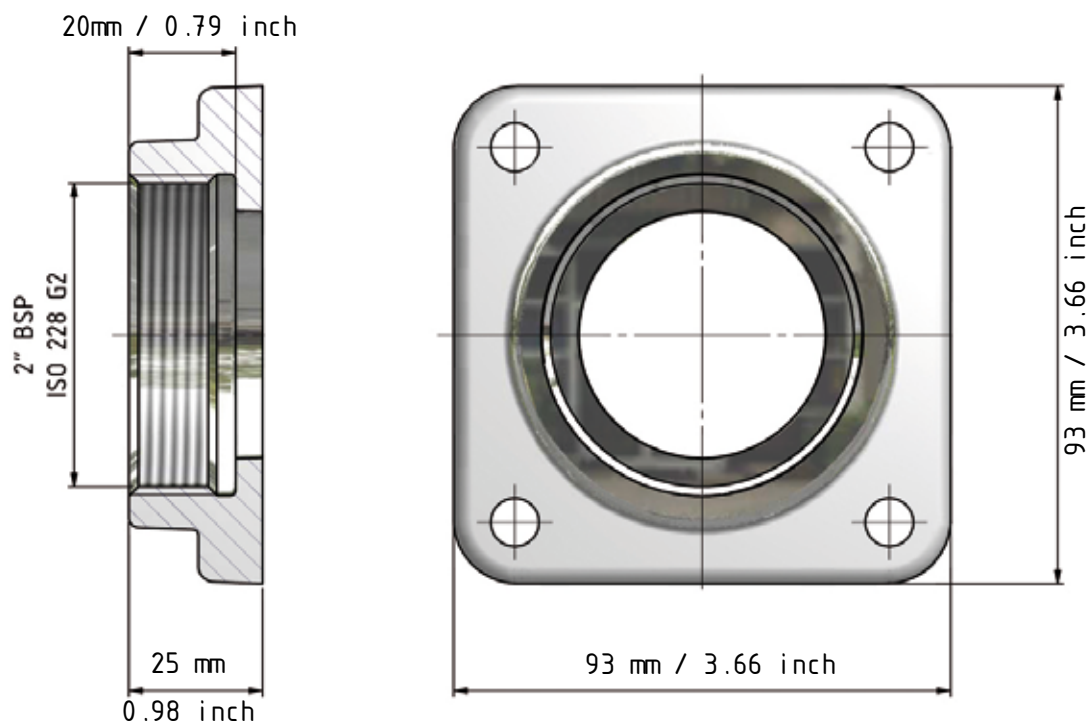

**Code No. 1383-1B**

**2" / DN 50 2" BSP Female thread flange, Steel**

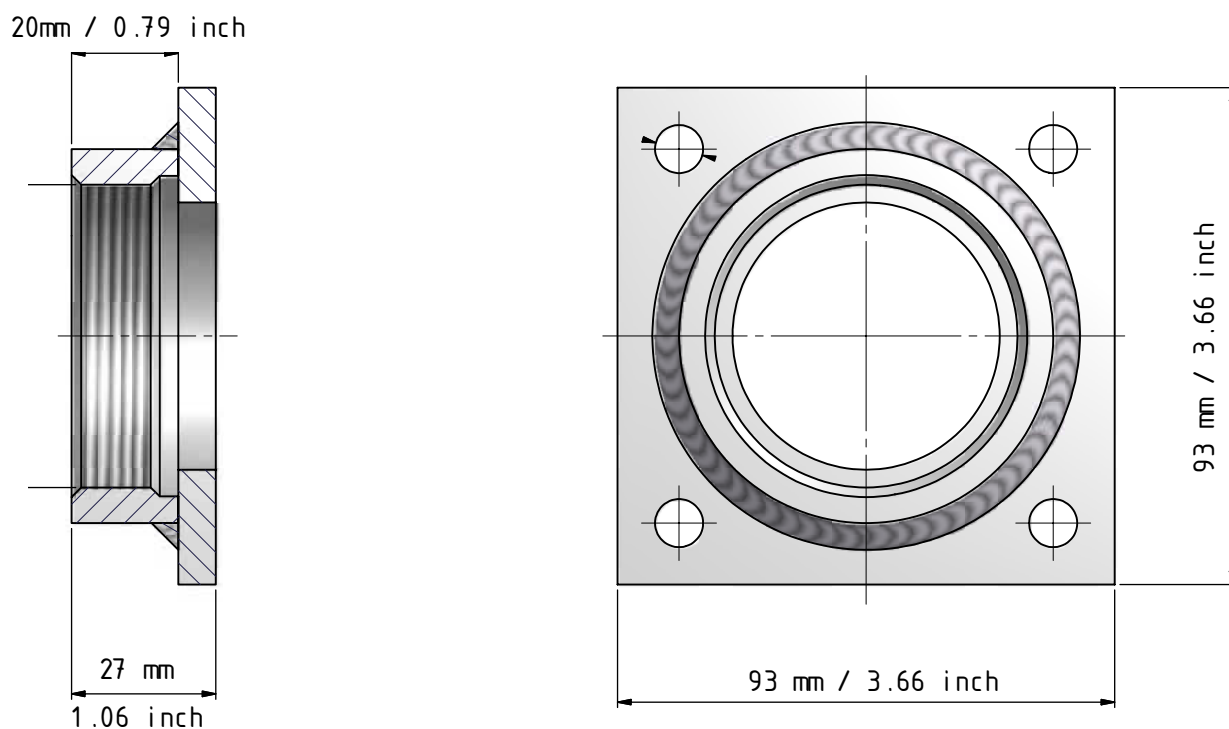

**Code No. 1383-3**

**2" / DN 50 2" NPT Female thread flange, Aluminium**

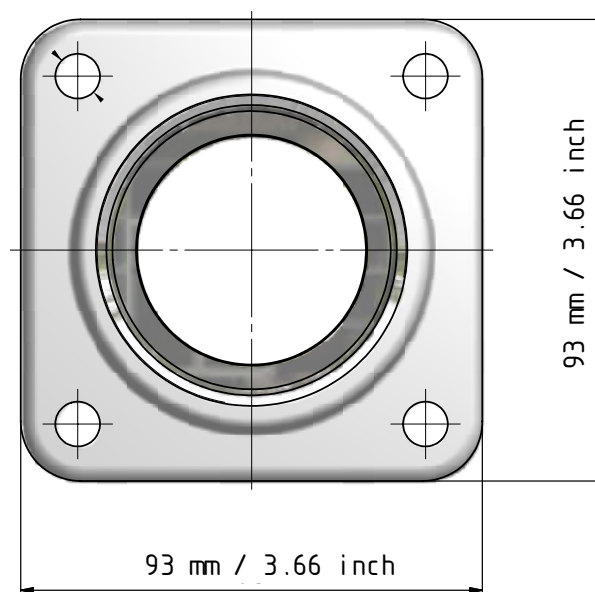
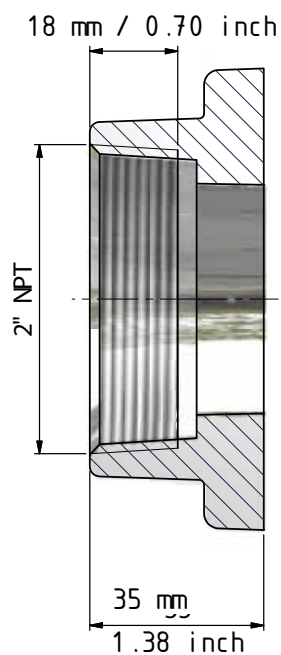

**Code No. 1725-1B**

**2" / DN 50 2" BSP Male thread flange, Aluminium**

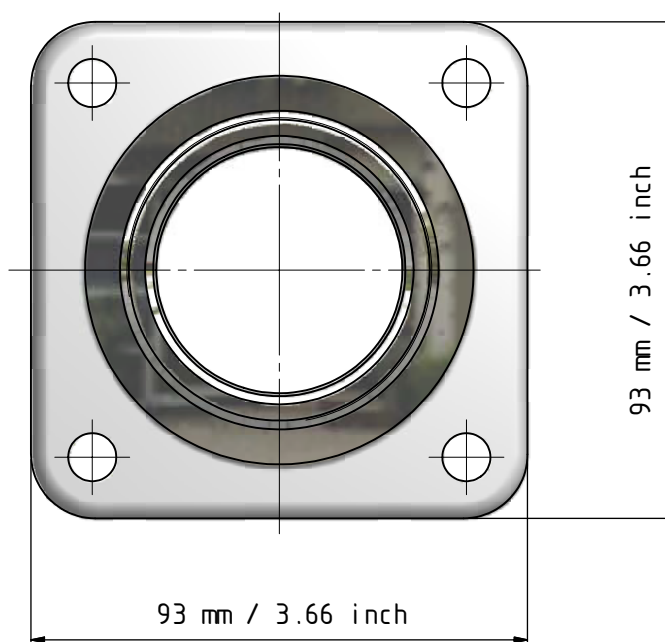
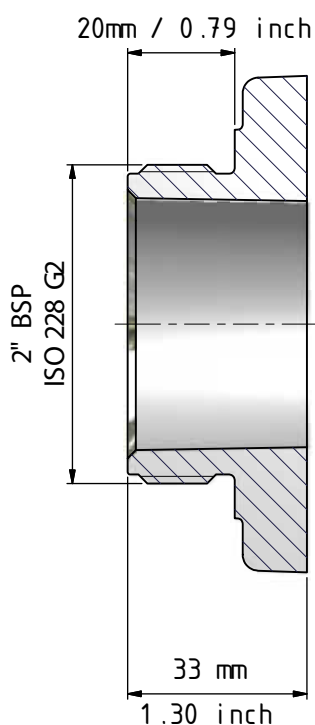

**Code No. 1378-1**

**2" / DN 50 2" BSP Male thread flange, Steel**

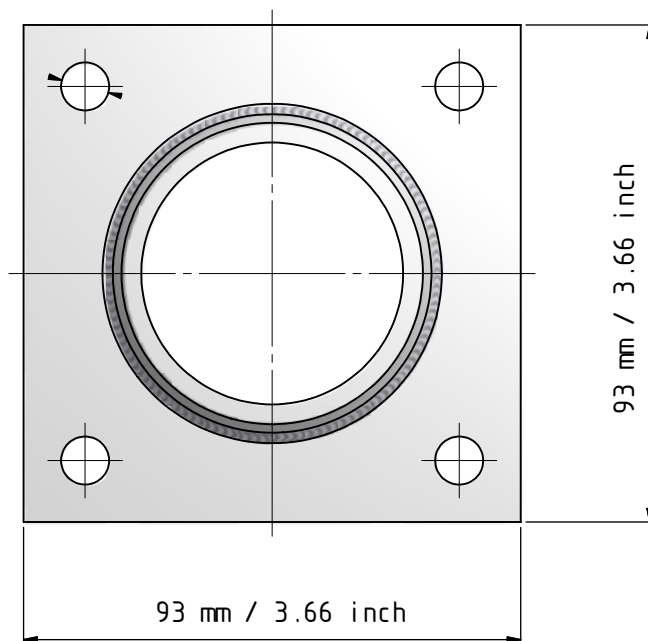
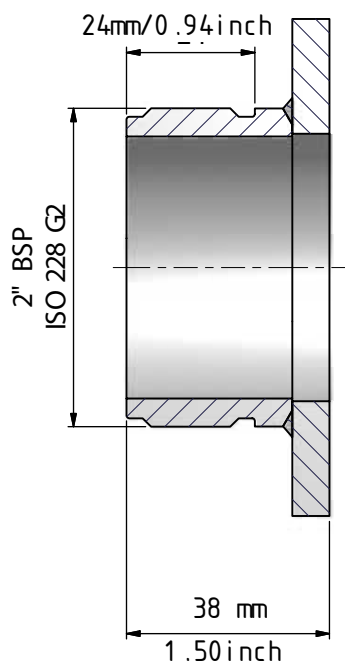

**Code No. 1378-3**

**2" / DN 50 2" TW1 / 50, Aluminium**

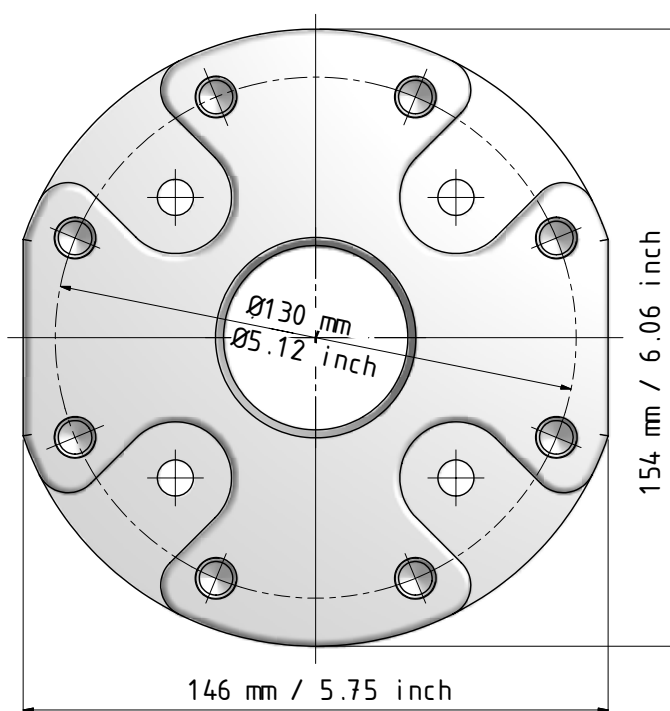
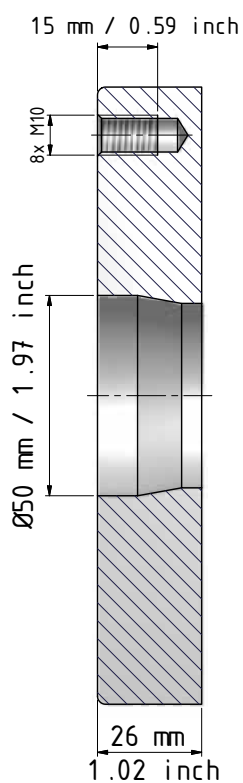

**Code No. 2449**

**2" / DN 50 2" TW1 / 50, Aluminium**

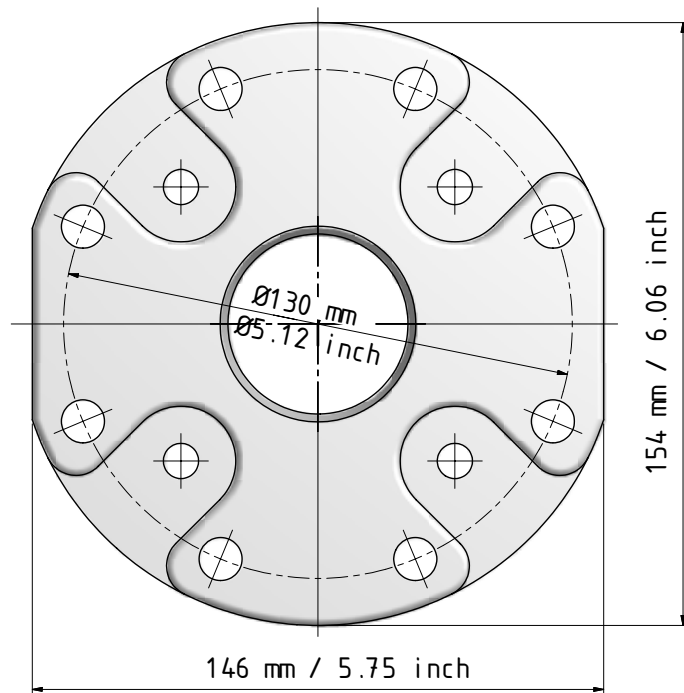
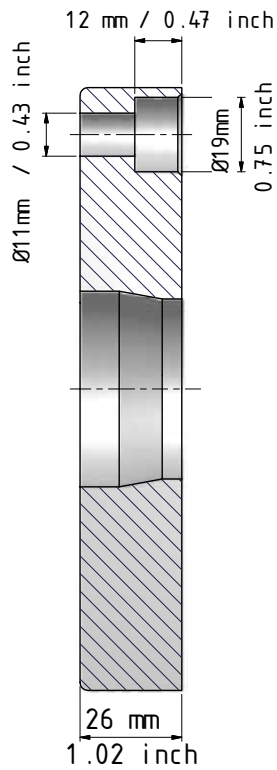

**Code No. 2450**

**2" / DN 50 2" ANSI - 150 psi, Aluminium**

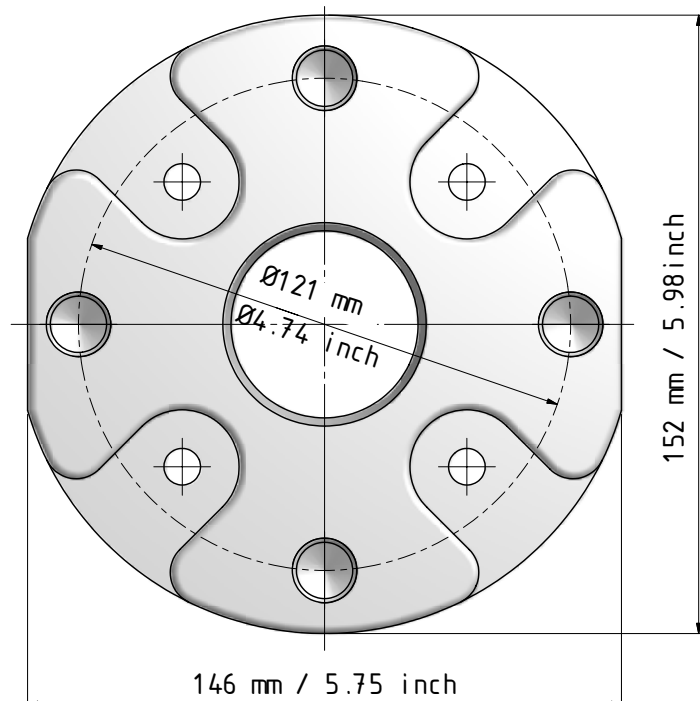
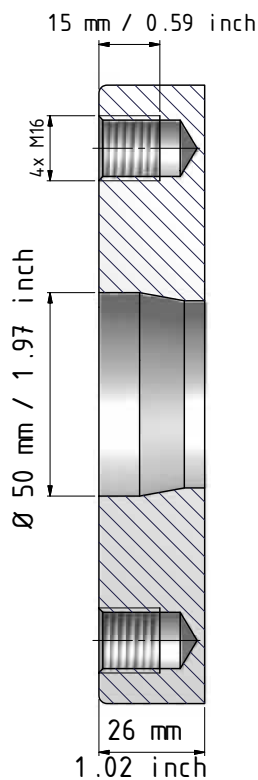

**Code No. 2525**



**2" / DN 50 2" Welding flange W Ø57 mm, Aluminium**

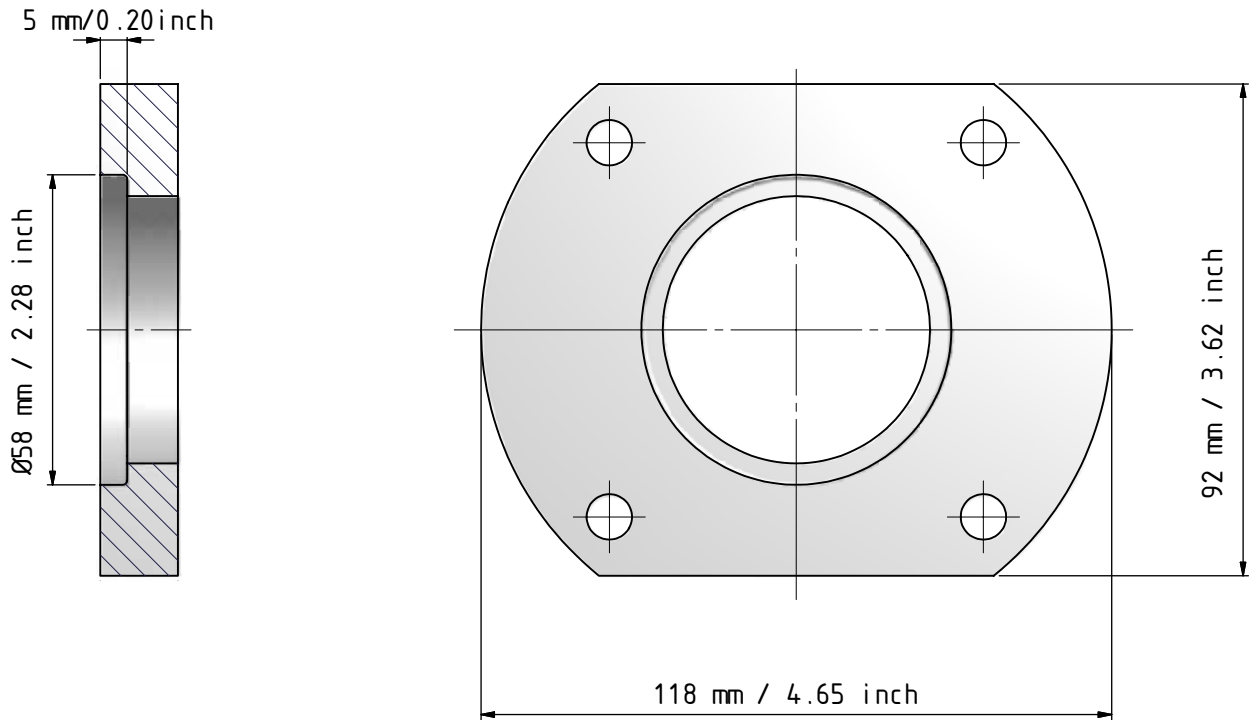

**Code No. 1335-1**

**2" / DN 50 2" Welding flange W Ø60 mm, Steel**

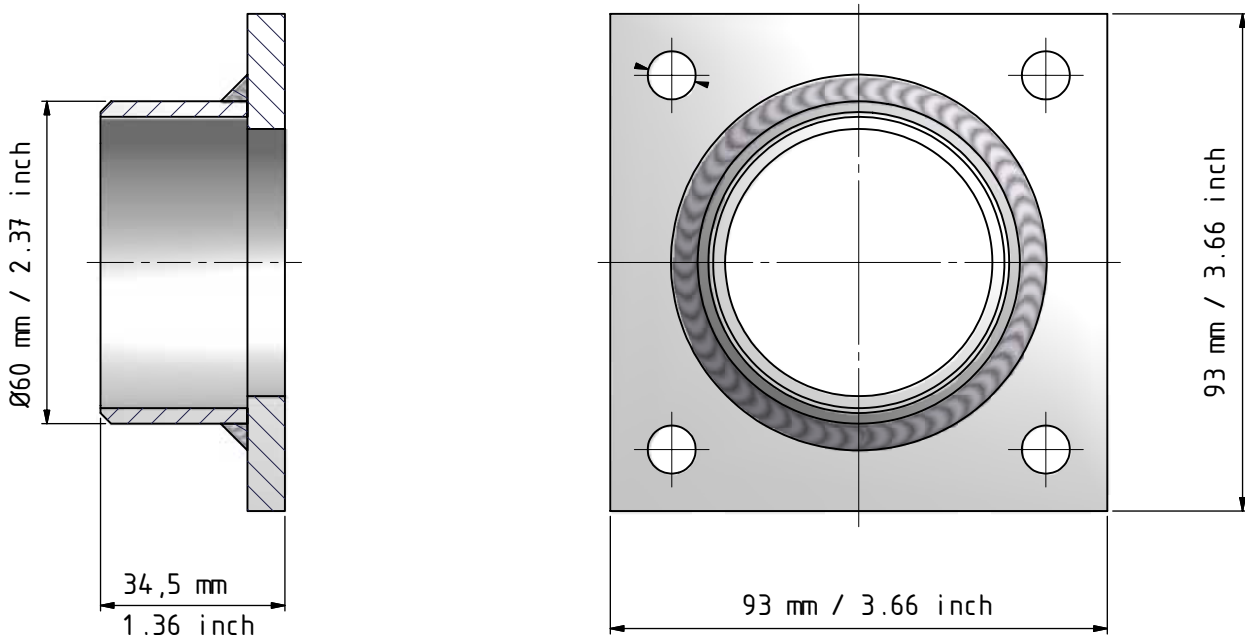

**Code No. 1376-3**

**2" / DN 50 2" Welding flange W Ø60 mm, Steel**

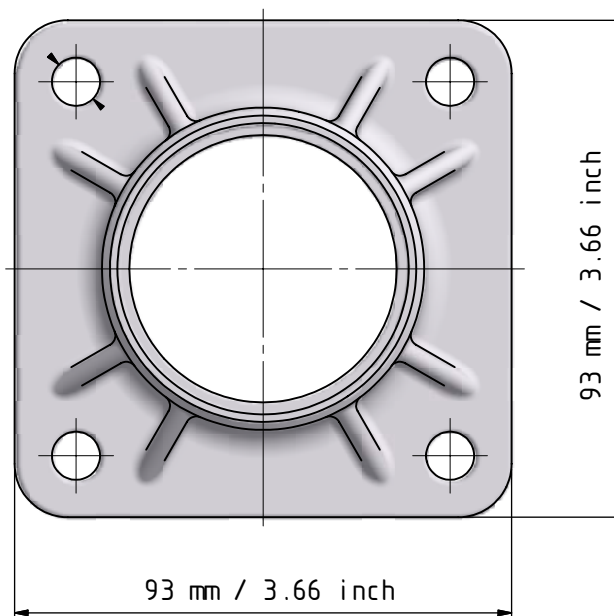
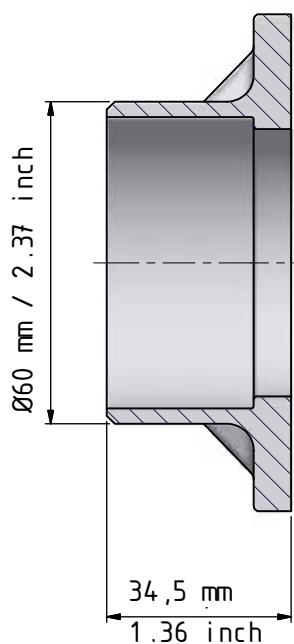

**Code No. 1376-3B**

**2" / DN 50 2" Welding flange W Ø60 mm, Stainless Steel**

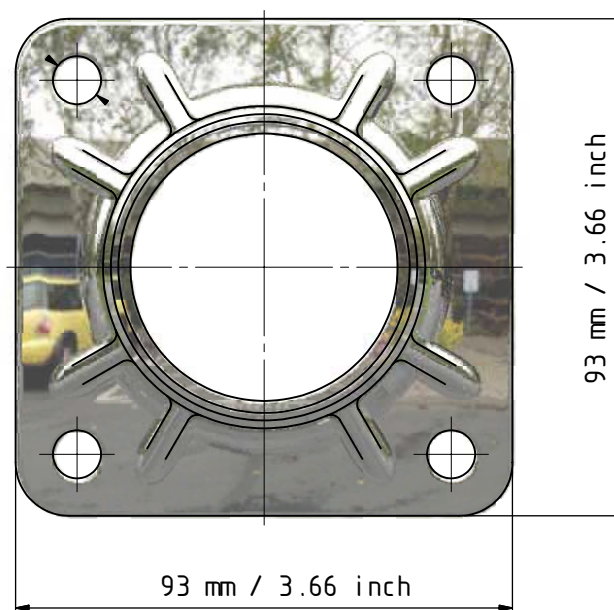
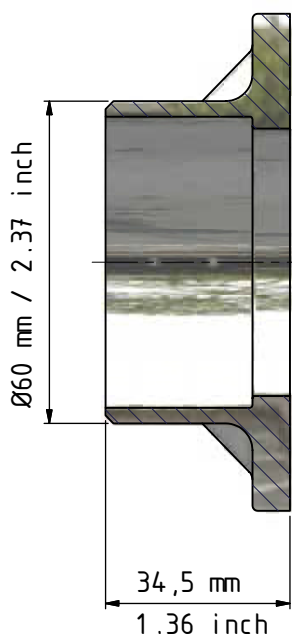

**Code No. 1376-4B**

**2" / DN 50 2" Welding flange Ø57 mm, Aluminium**

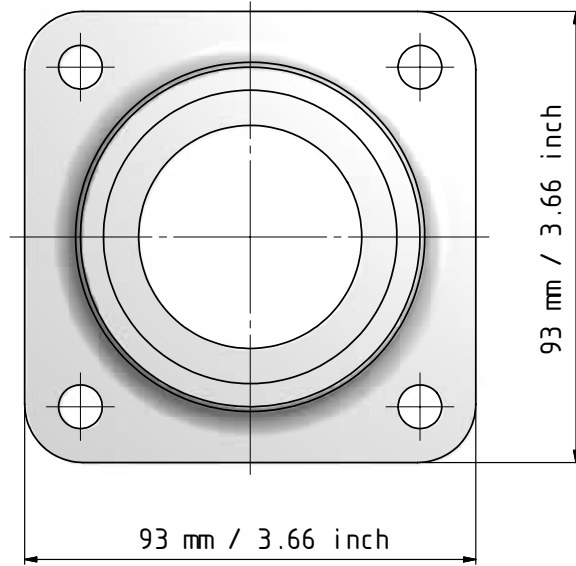
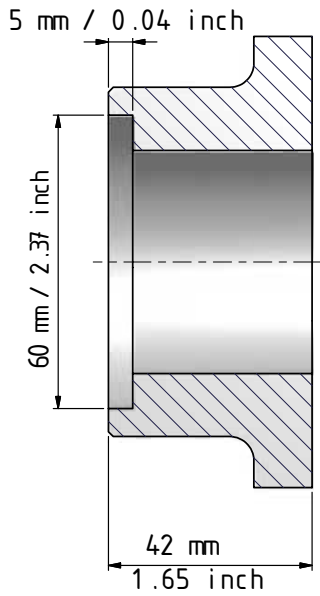

**Code No. 1926-1**

**3" / DN 80 3" BSP Female thread flange, Aluminium**

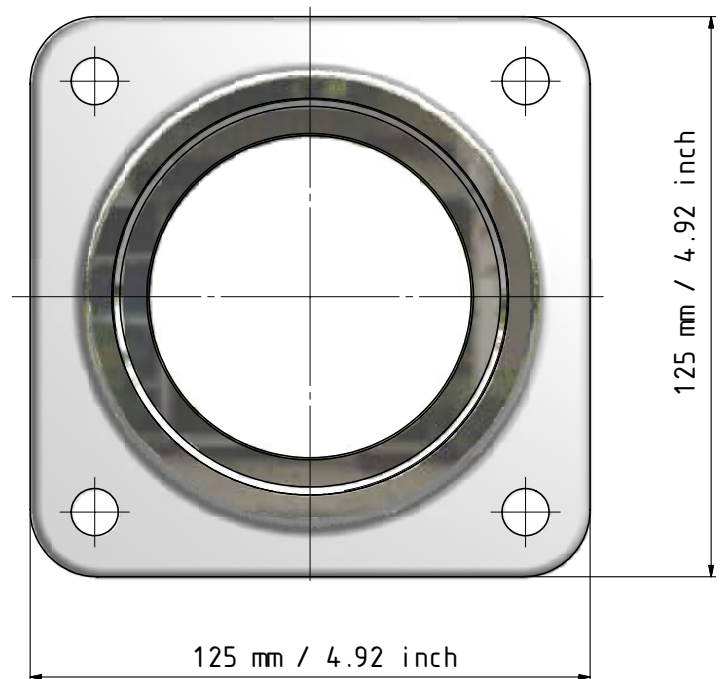
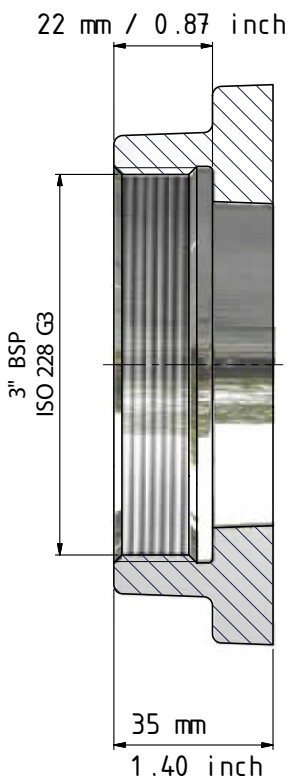

**Code No. 1322-1B**

**3" / DN 80 3" BSP Female thread flange, Steel**

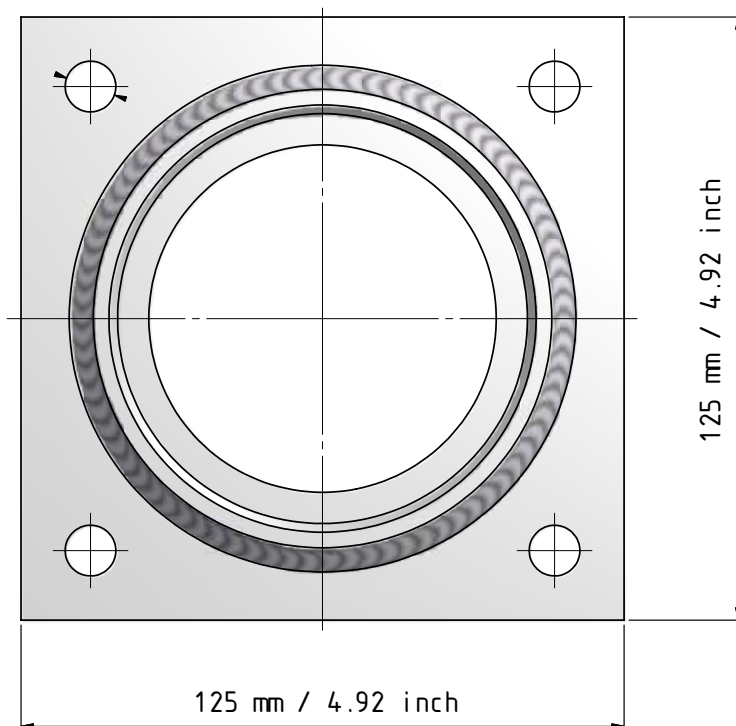
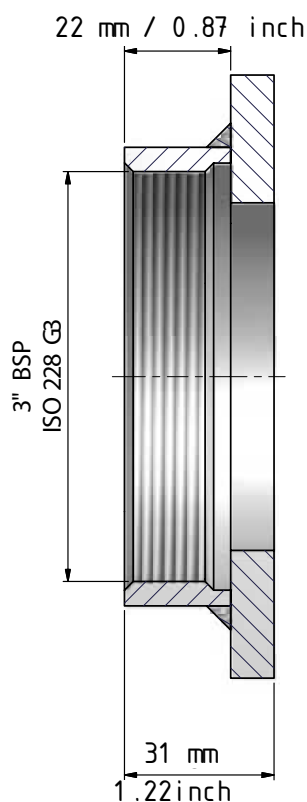

**Code No. 1322-3**

**3" / DN 80 3" NPT Female thread flange, Aluminium**

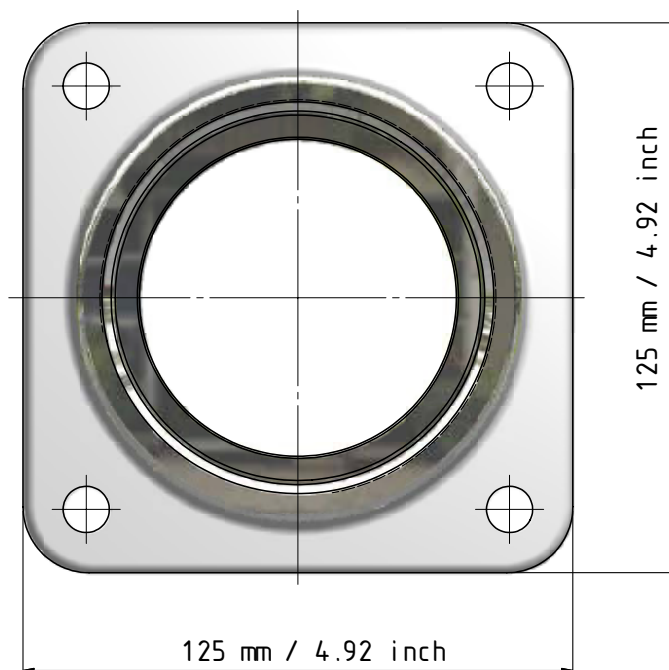
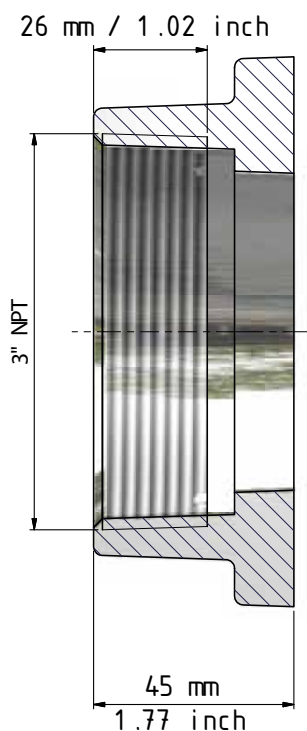

**Code No. 1827-1B**

**3" / DN 80 3" BSP Male thread flange, Aluminium**

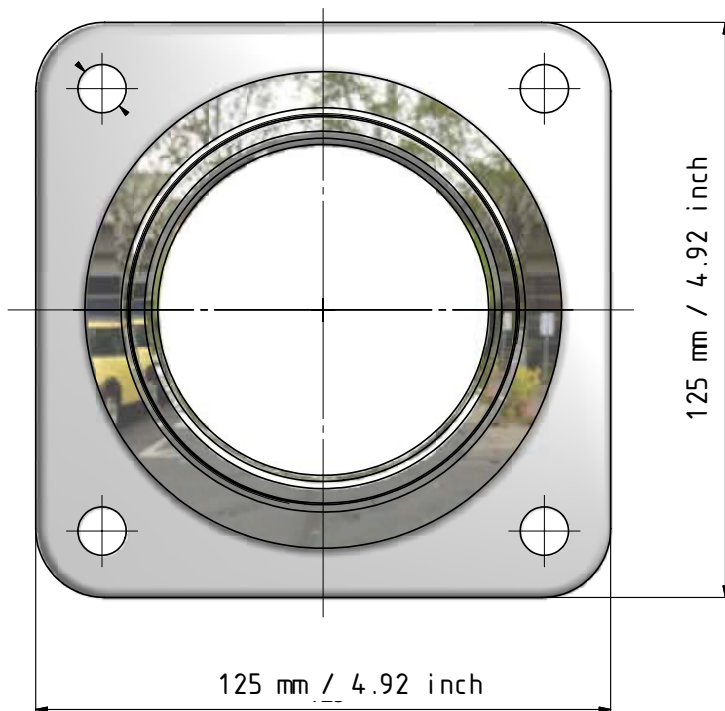

**Code No. 1329-1B**

**3" / DN 80 3" BSP Male thread flange, Steel**

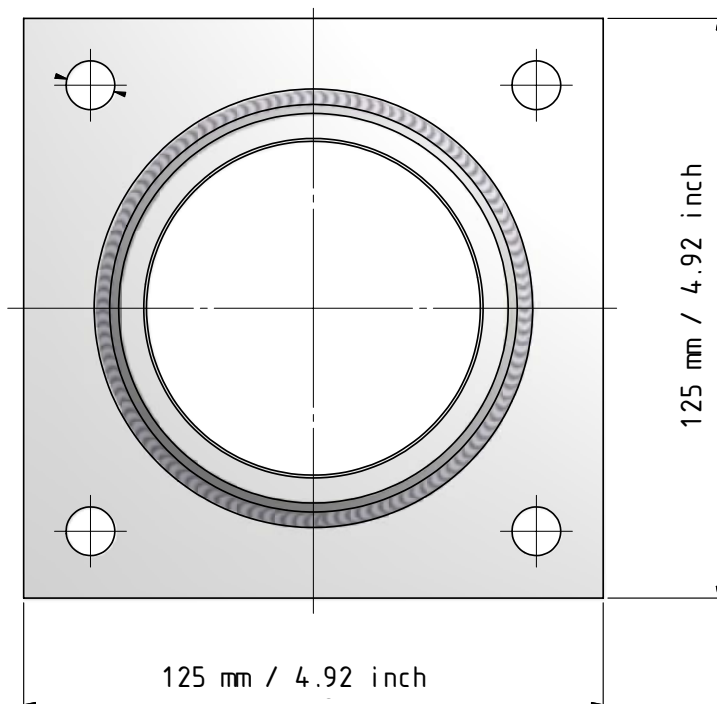
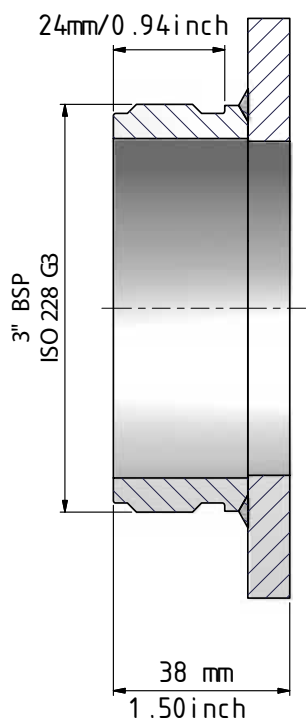

**Code No. 1329-3**



**3" / DN 80 3" PN 10/16, Aluminium**

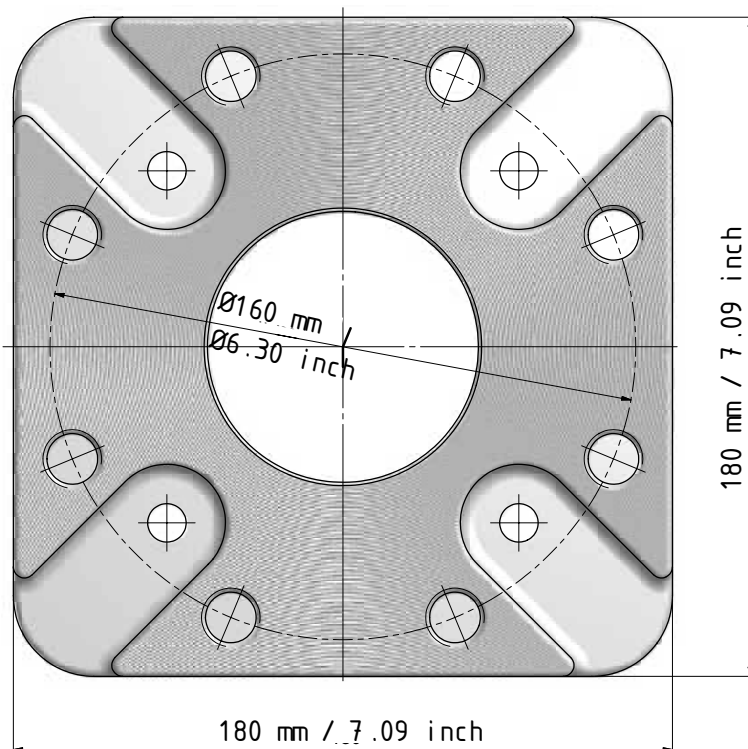
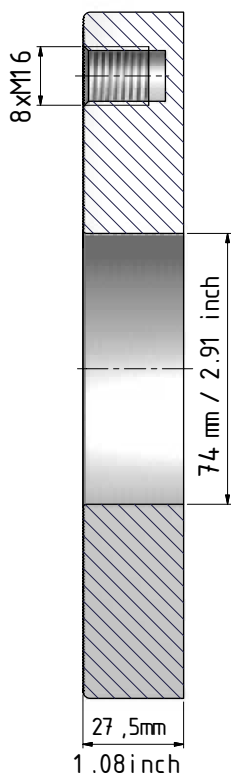

**Code No. 2047-1**

**3" / DN 50 2" TW1 / 50, Aluminium**

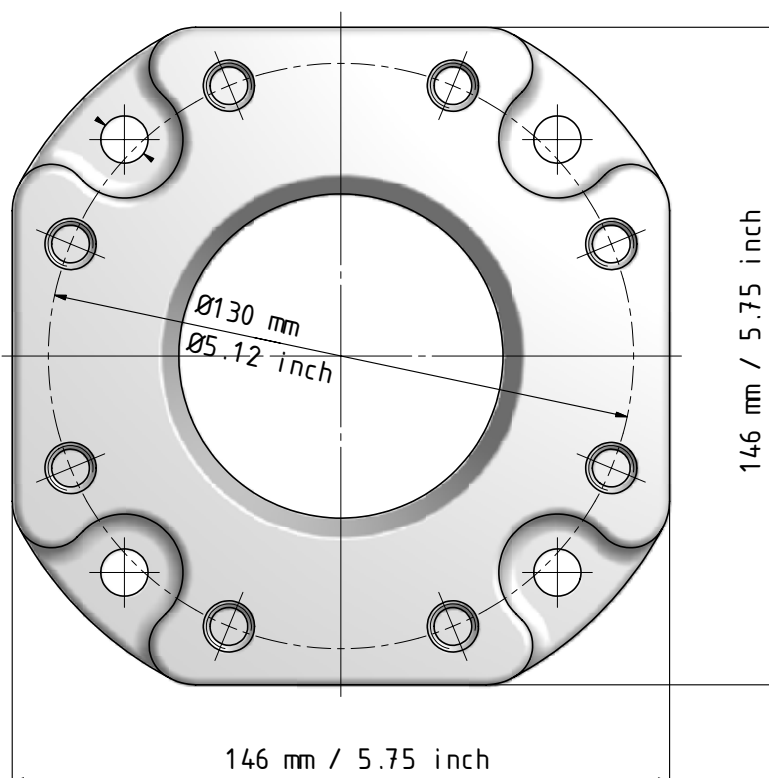
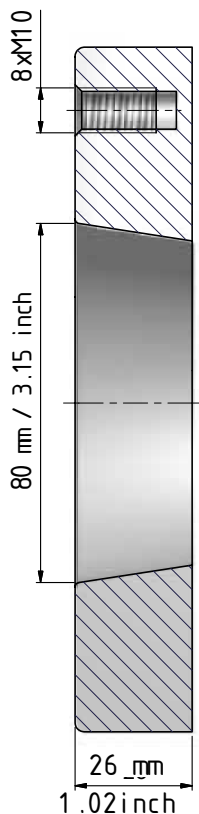

**Code No. 1327-1**

**3" / DN 80 3" TW 1 / 80, Aluminium**

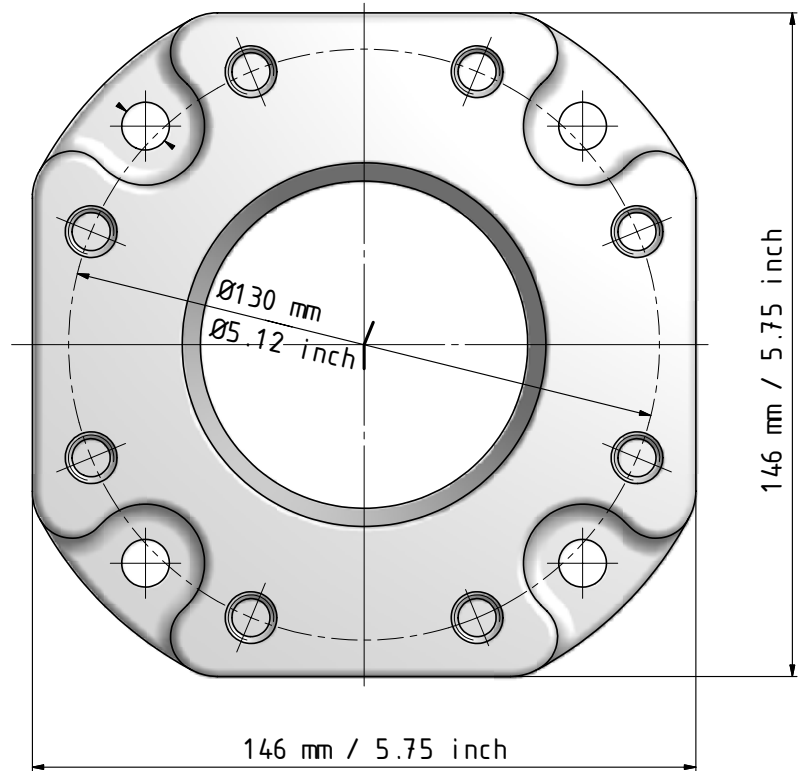
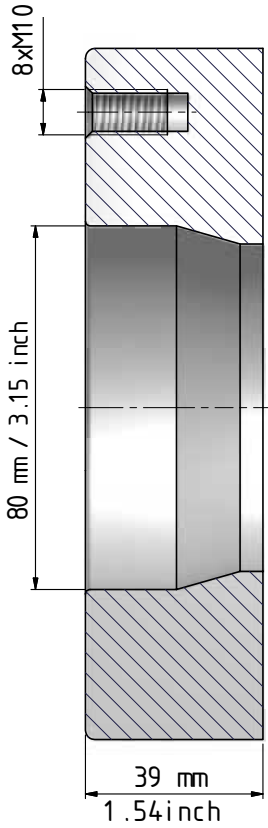

**Code No. 1325-1**

**3" / DN 80 3" TW 1 / 80, Aluminium**

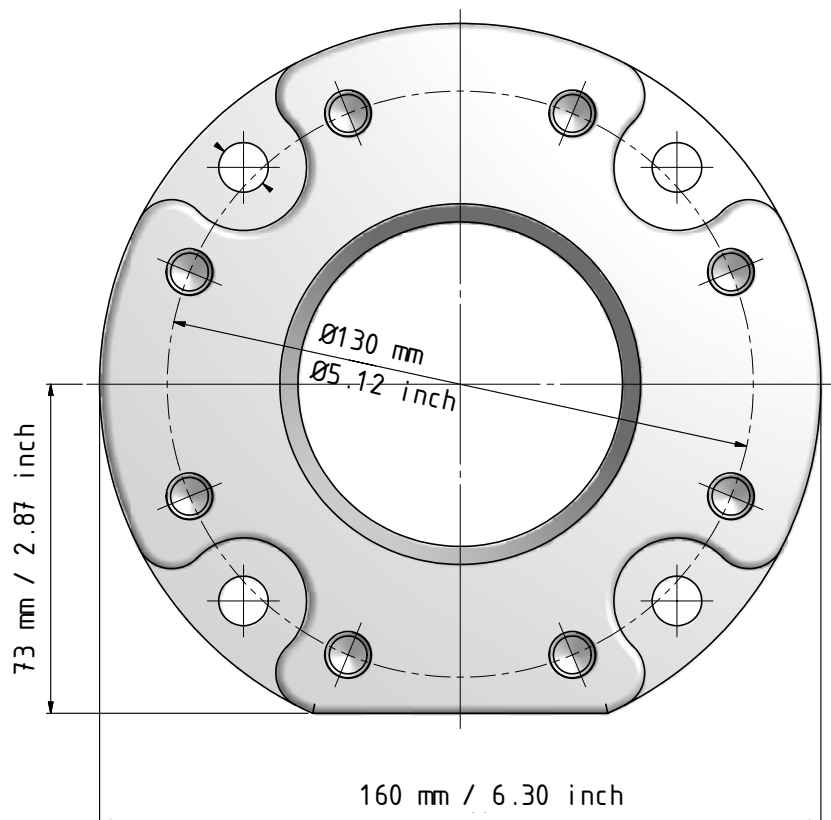
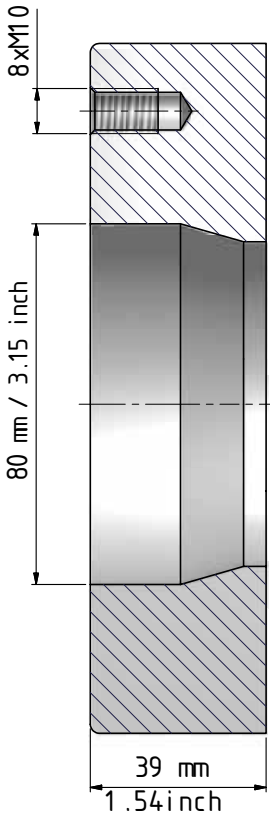

**Code No. 1325-1BT**

**3" / DN 80 3" ANSI - 150 psi, Aluminium**

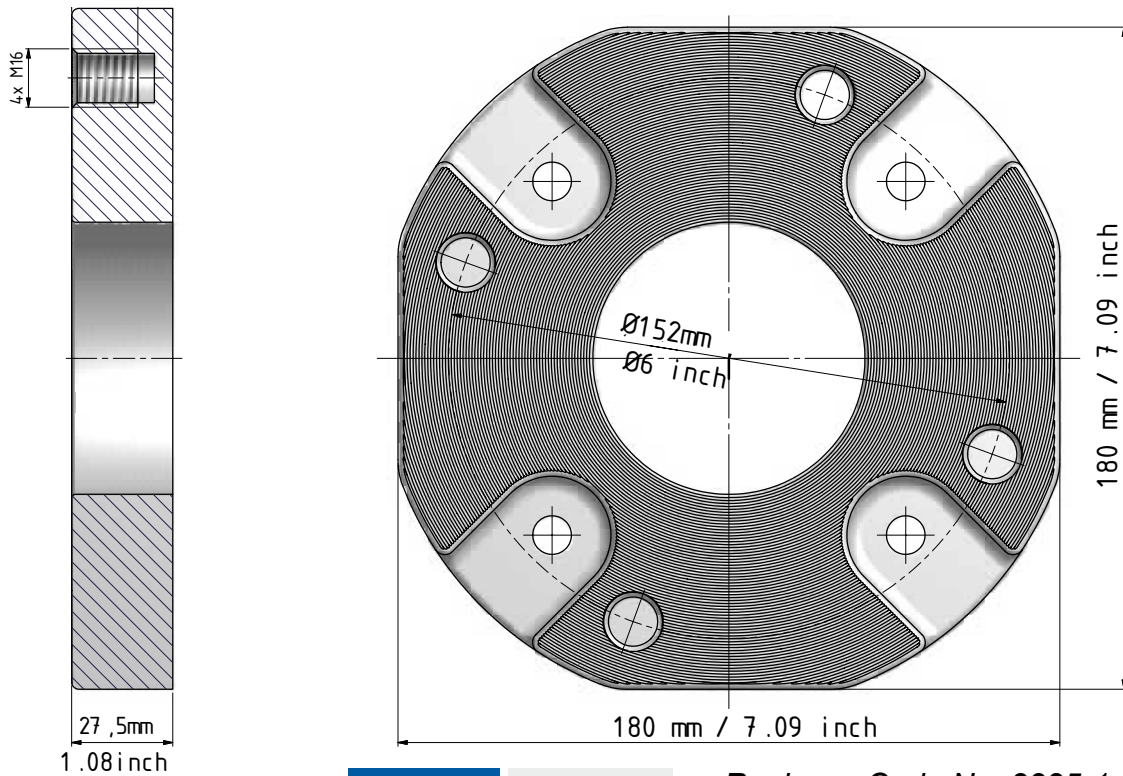

**Code No. 2599-1** Replaces Code No 2225-1

**3" / DN 80 3" Welding flange Ø73 mm, Stainless Steel**

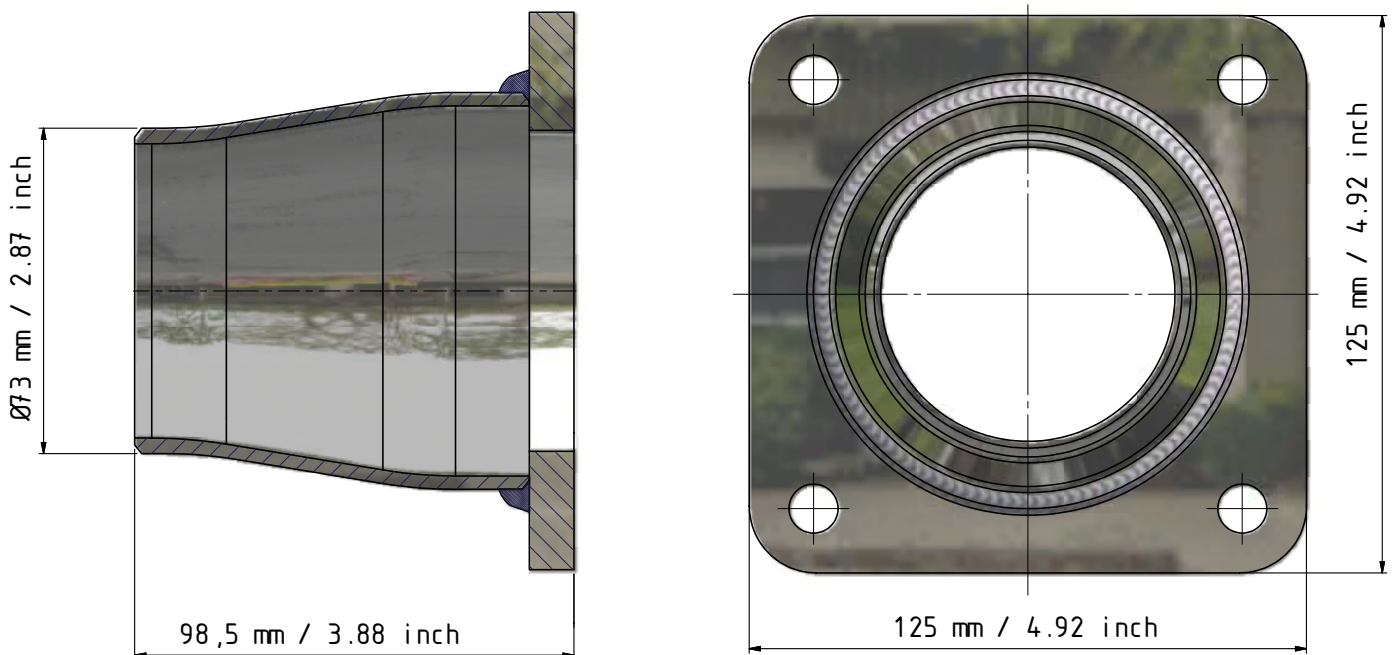

**Code No. 2472-4**

**3" / DN 80 3" Welding flange Ø76 mm, Aluminium**

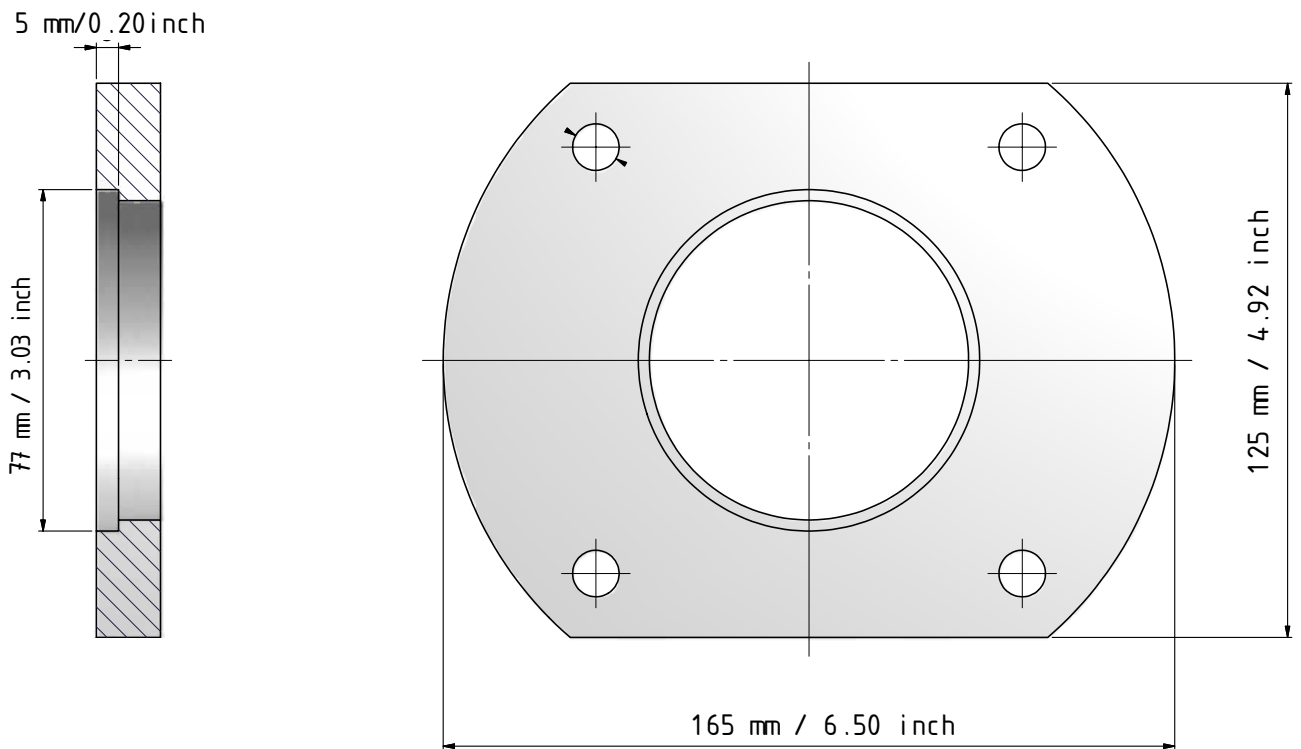

**Code No. 1338-1**

**3" / DN 80 3" Welding flange Ø76 mm, Steel**

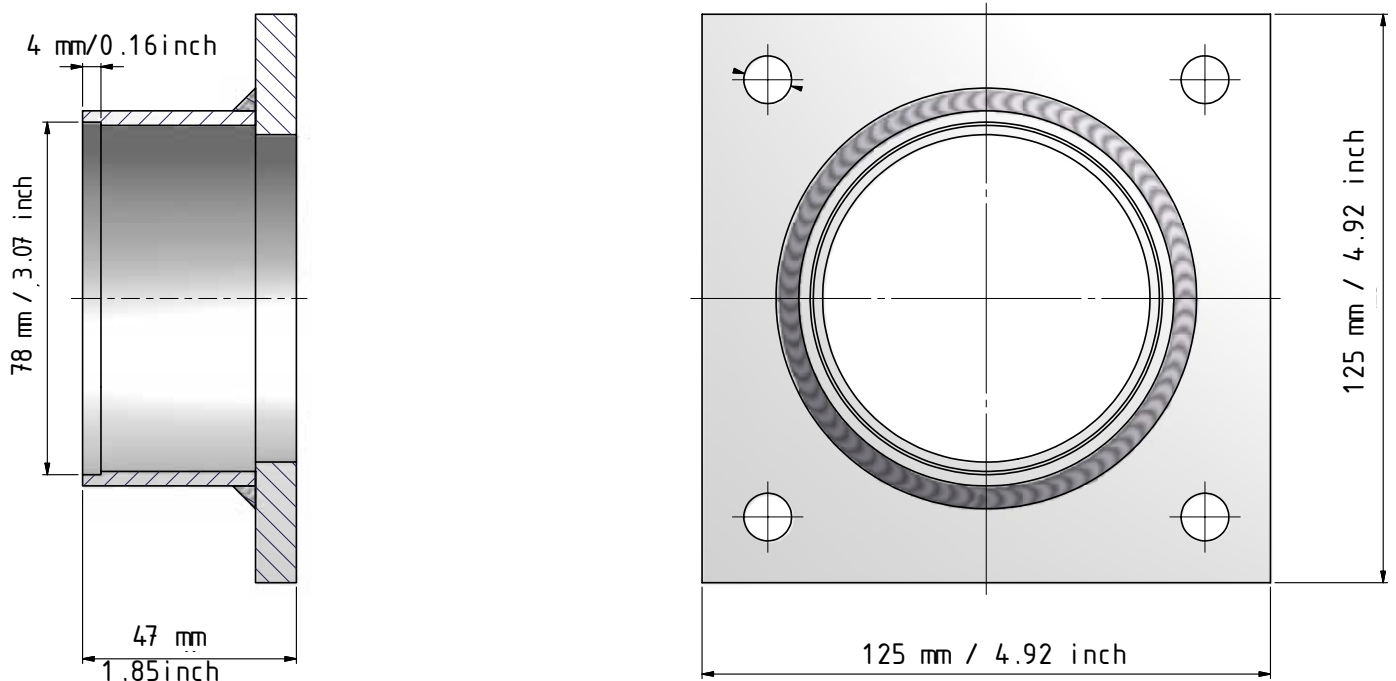

**Code No. 1338-3**

**3" / DN 80 3" Welding flange Ø89 mm, Aluminium**

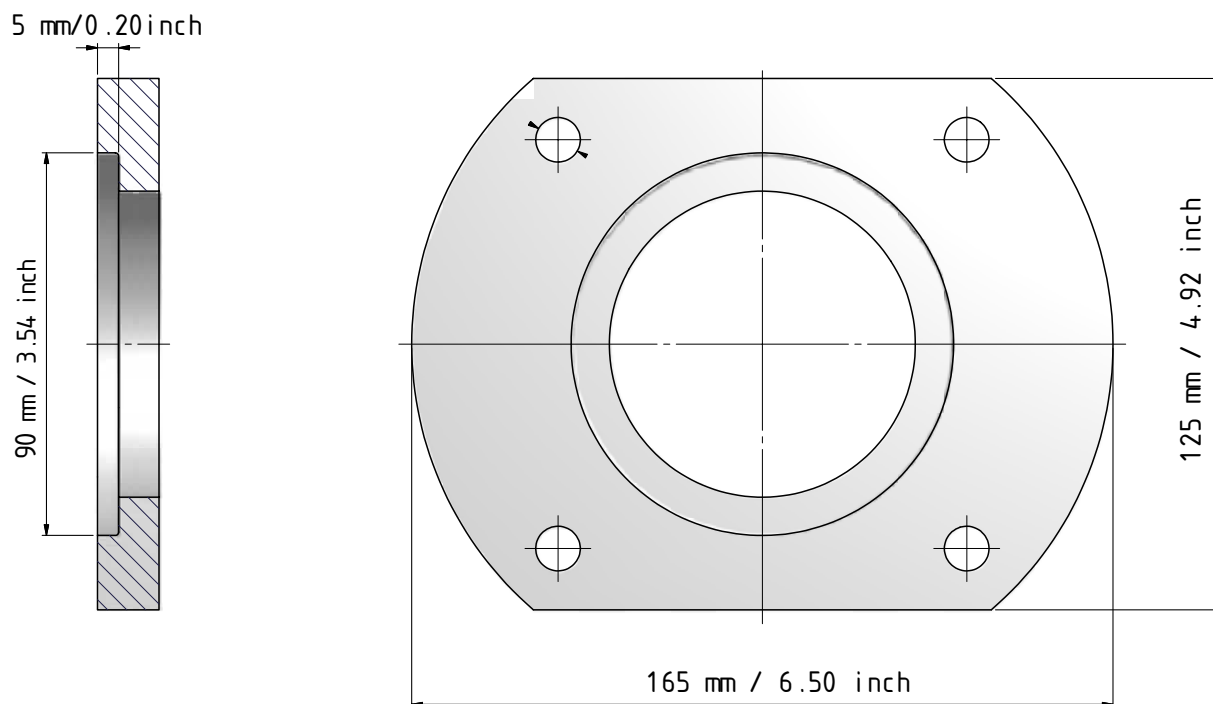

**Code No. 1340-1**

**3" / DN 80 3" Welding flange Ø89 mm, Steel**

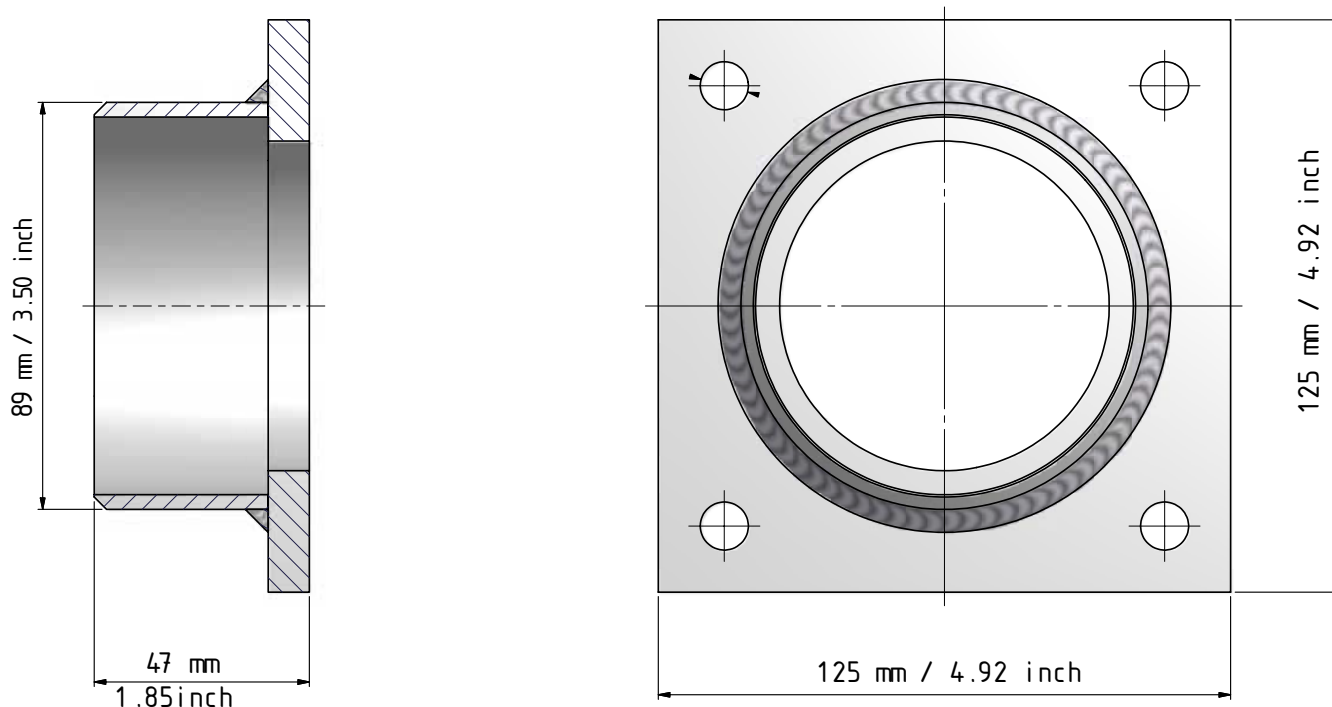

**Code No. 1340-3**



**3" / DN 80 3" Welding flange Ø89 mm, Steel**

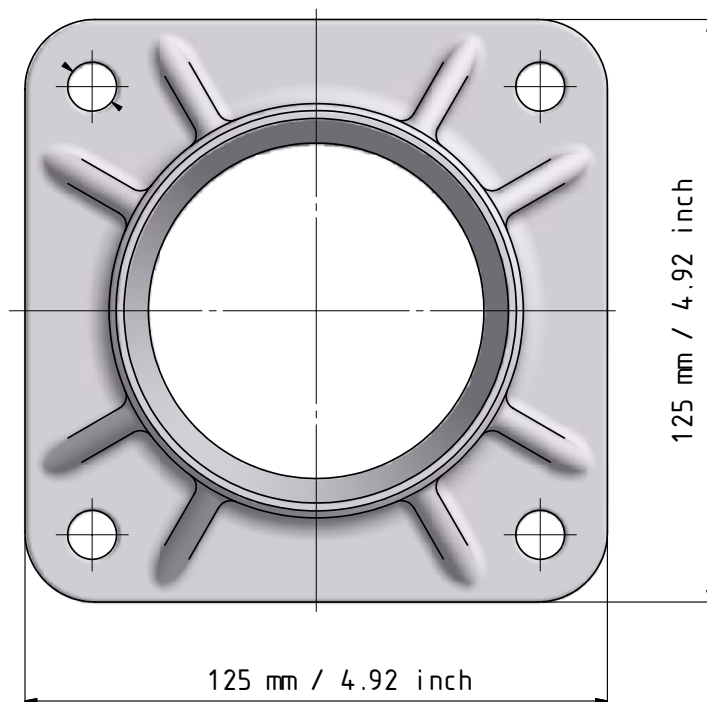
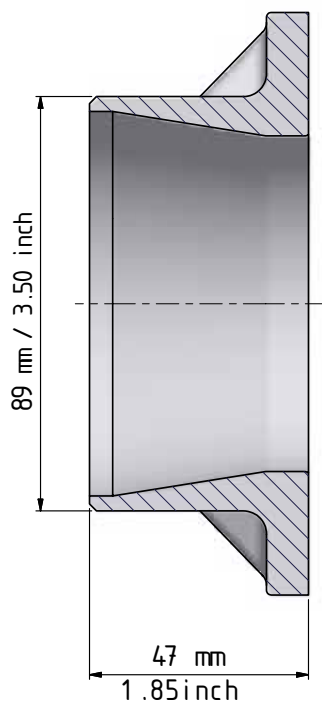

**Code No. 1340-3B**

**3" / DN 80 3" Welding flange Ø89 mm, Stainless Steel**

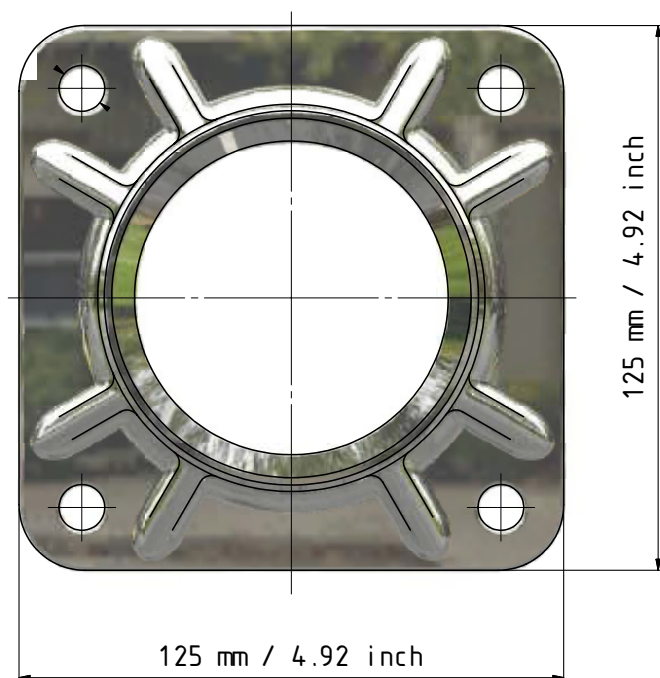
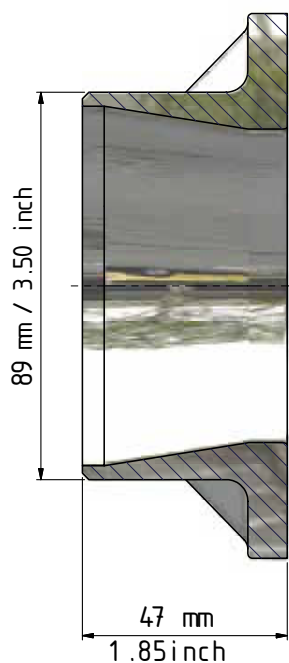

**Code No. 1340-4B**

**4" / DN 100 4" BSP Female thread flange, Aluminium**

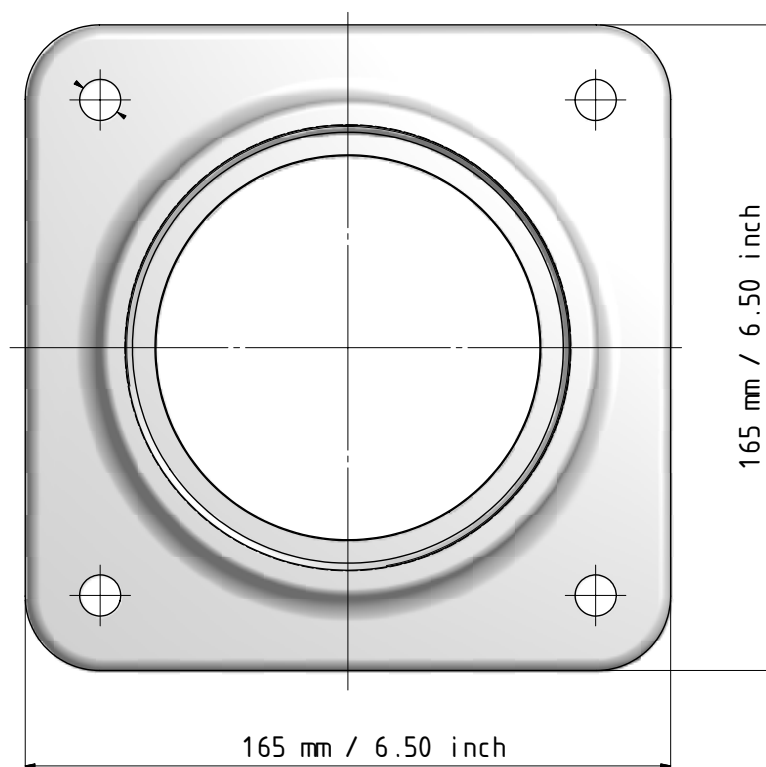
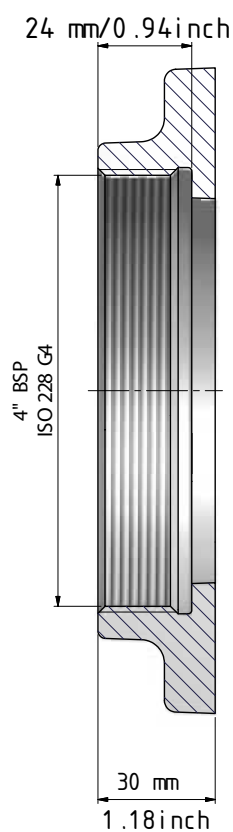

**Code No. 1315-1B**

**4" / DN 100 4" BSPT Female thread flange, Aluminium**

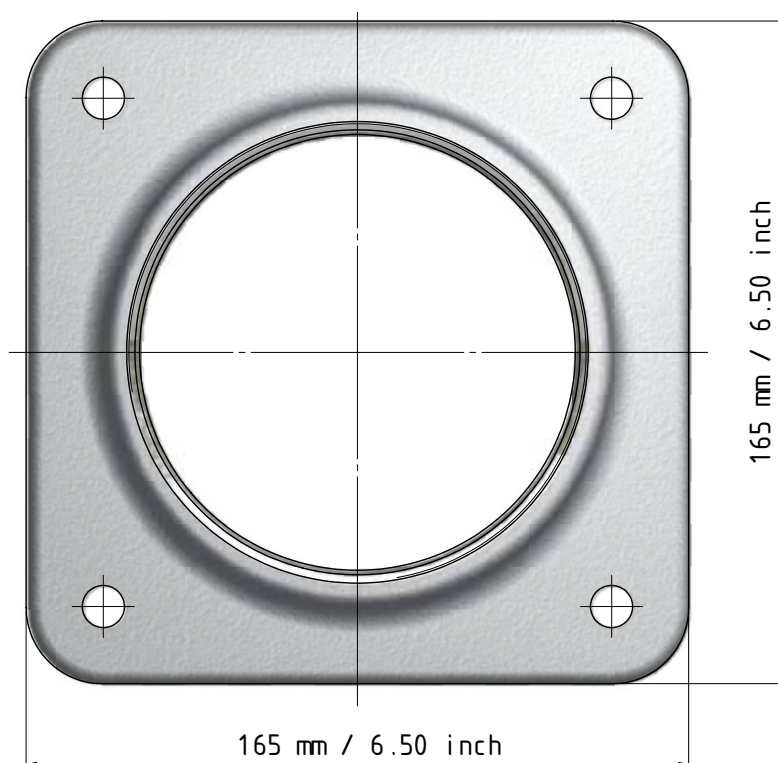
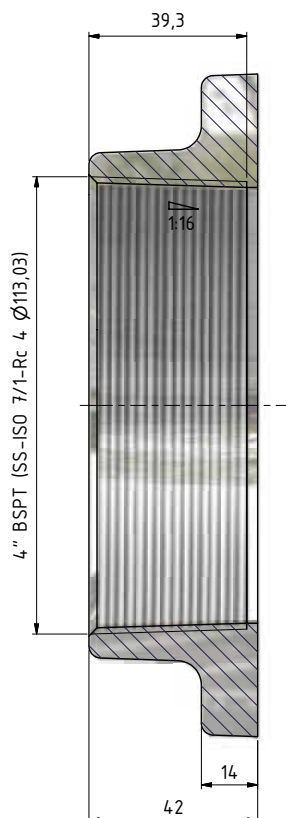

**Code No. 2669-1B**

**4" / DN 100 4" BSP Female thread flange, Steel**

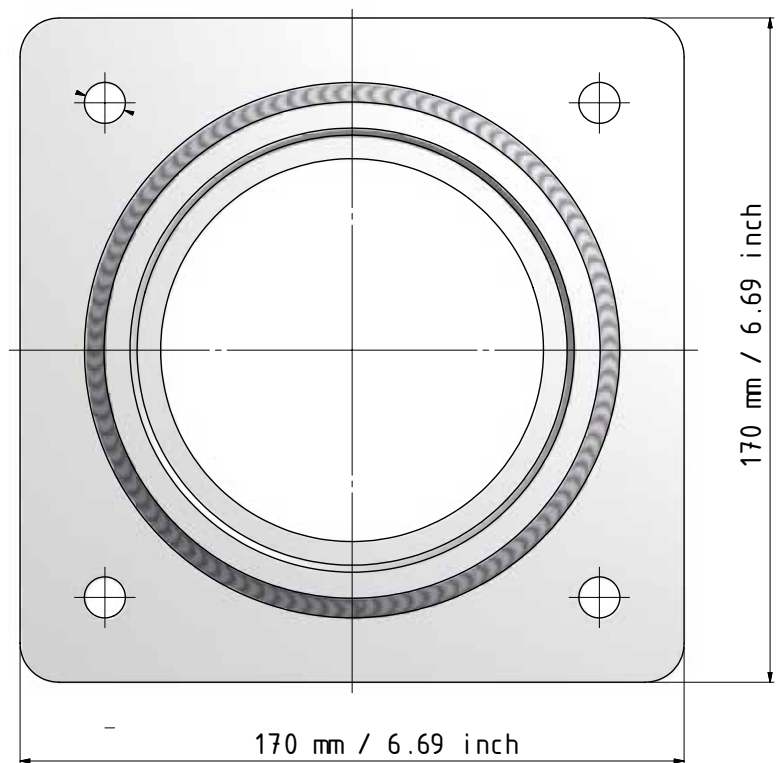
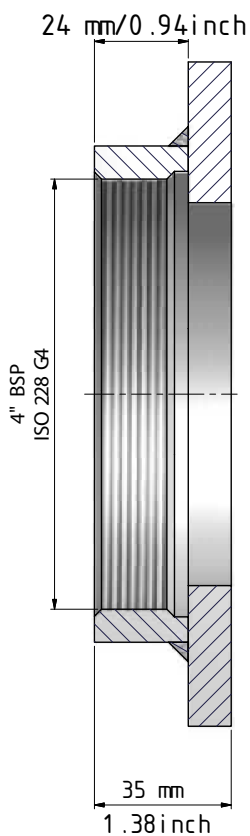

**Code No. 1315-3**

**4" / DN 100 4" NPT Female thread flange, Aluminium**

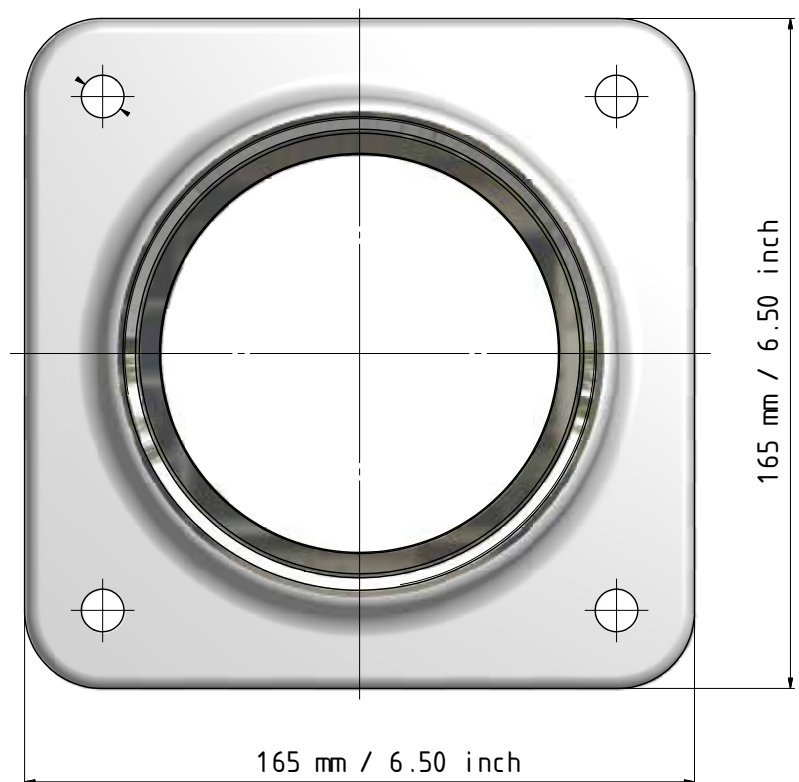
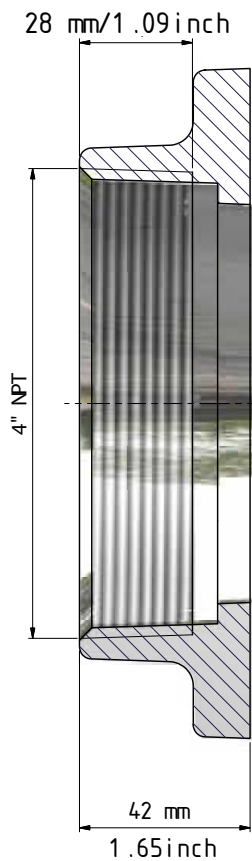

**Code No. 1829-1B**

**4" / DN 100 4" BSP Male thread flange, Aluminium**

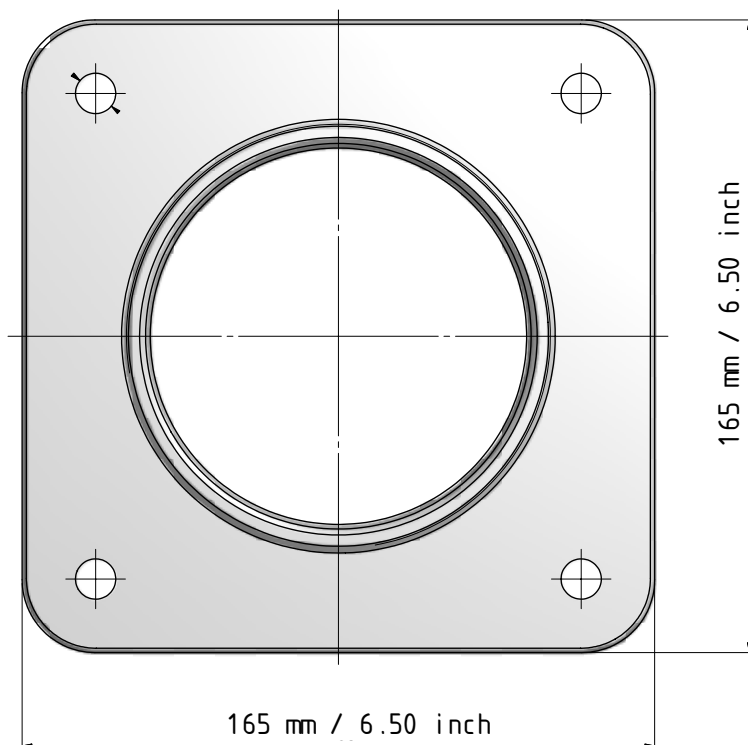
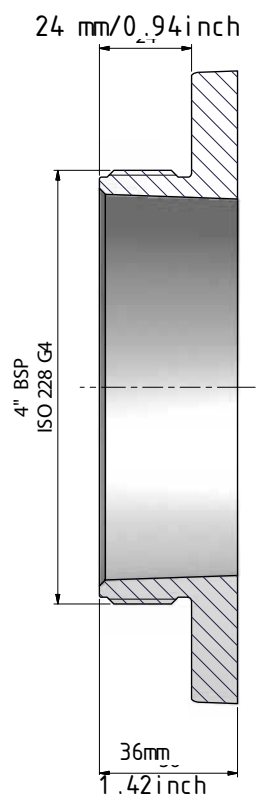

**Code No. 1379-1**

**4" / DN 100 4" BSP Male thread flange, Steel**

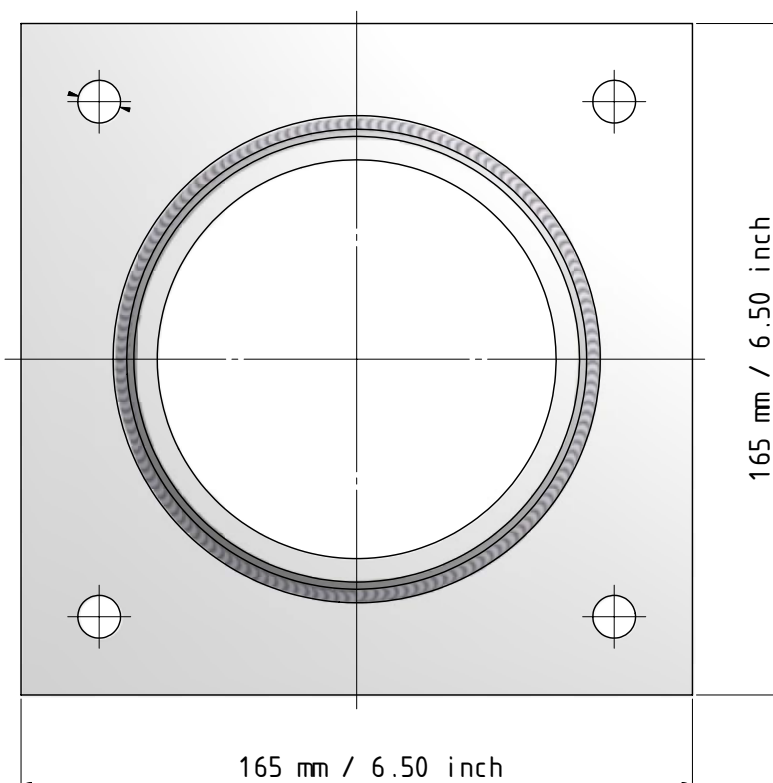
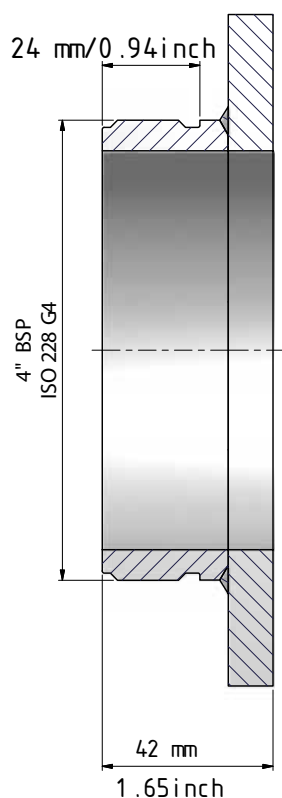

**Code No. 1379-3**

**4" / DN 100 4" PN 10/16, Aluminium**

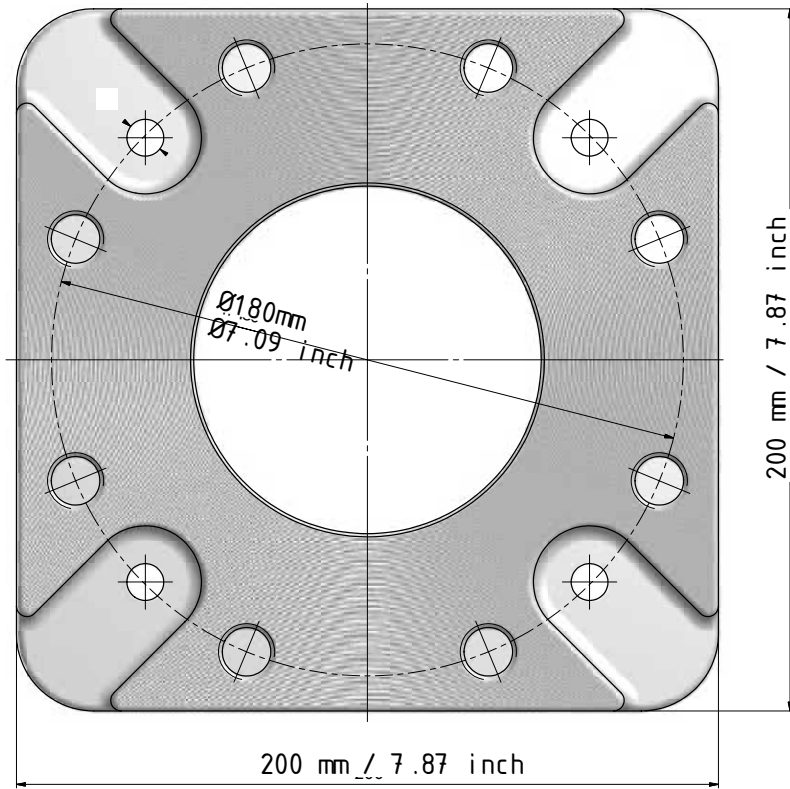
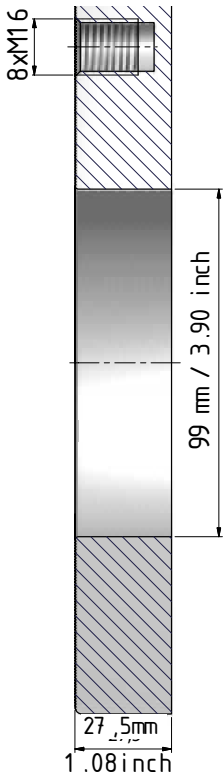

**Code No. 1929-1**

**4" / DN 100 4" TW3 / 100, Aluminium**

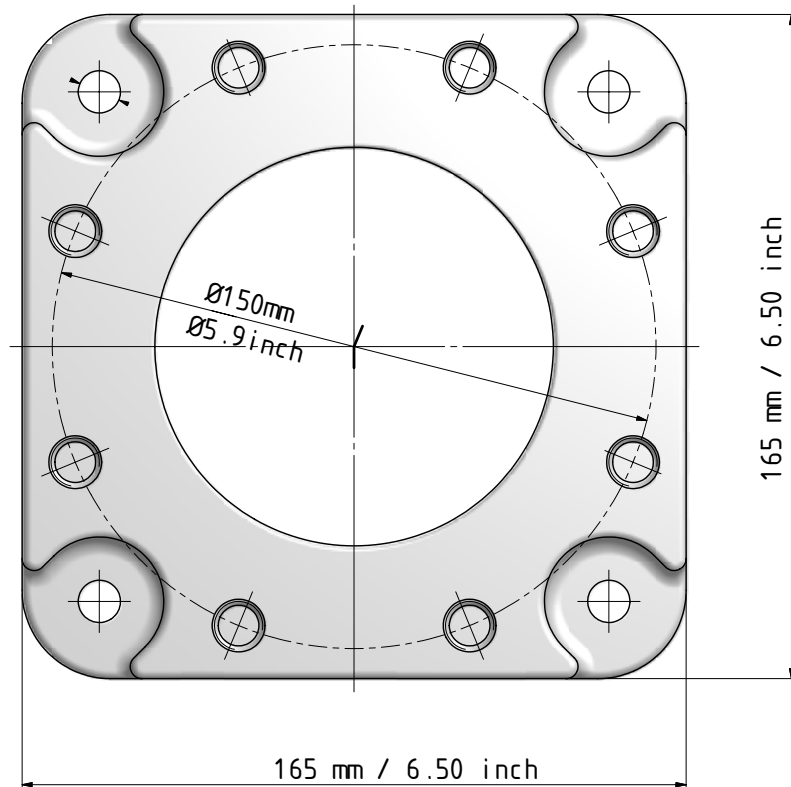
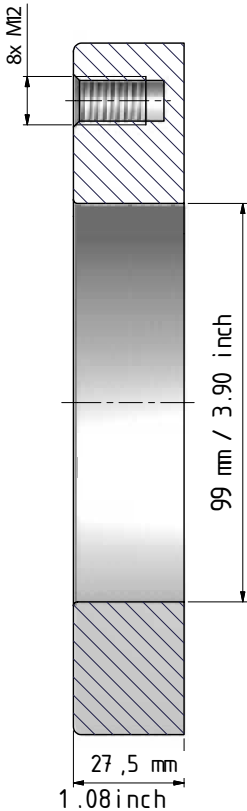

**Code No. 1326-1**



**4" / DN 100 4" ANSI 150 psi, Aluminium**

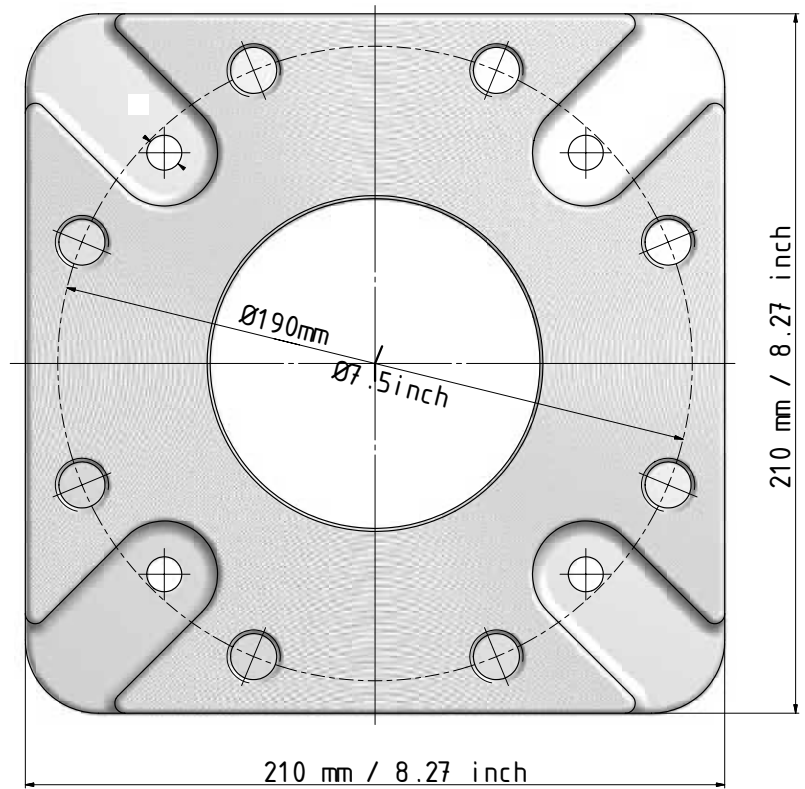
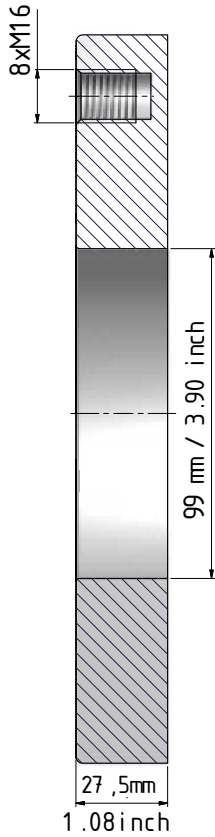

**Code No. 2171-1**

**4" / DN 100 4" Welding flange W Ø102 mm, Steel**

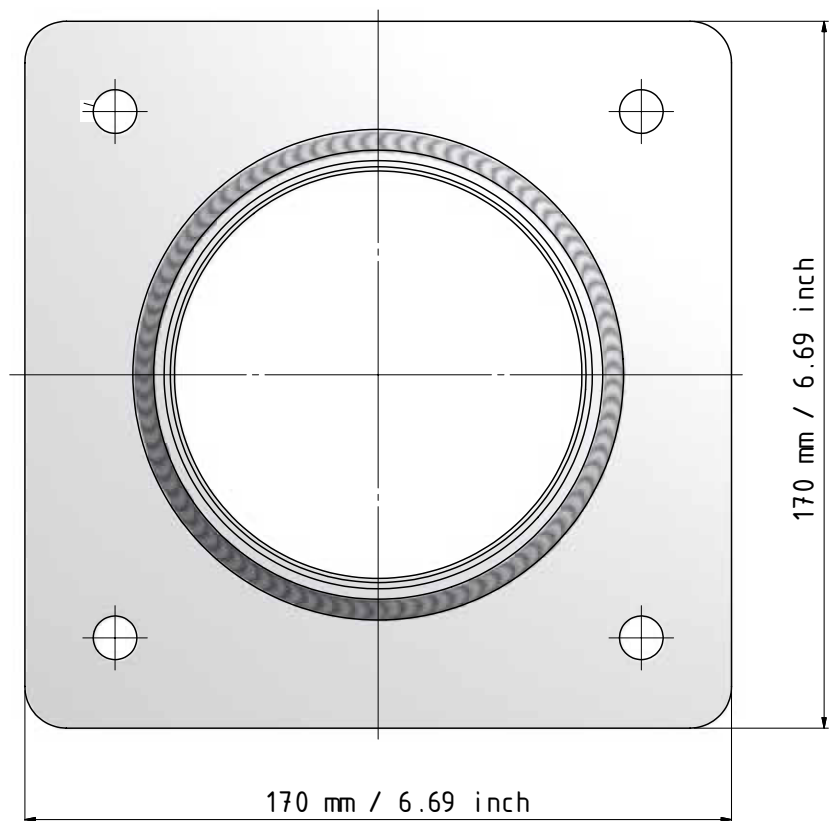
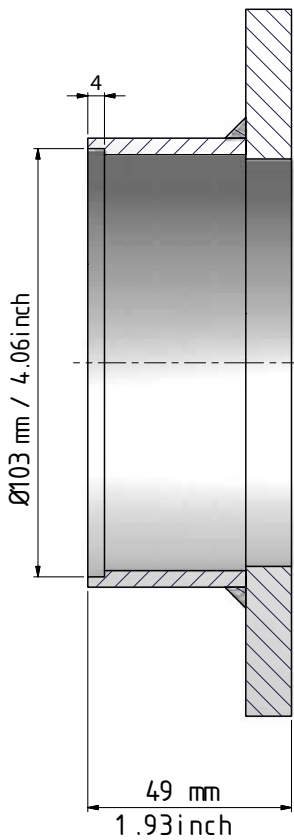

**Code No. 1360-3**

Specifications subject to change without notice - Copyright Mann Teknik AB

**4" / DN 100 4" Welding flange W Ø108 mm, Aluminium**

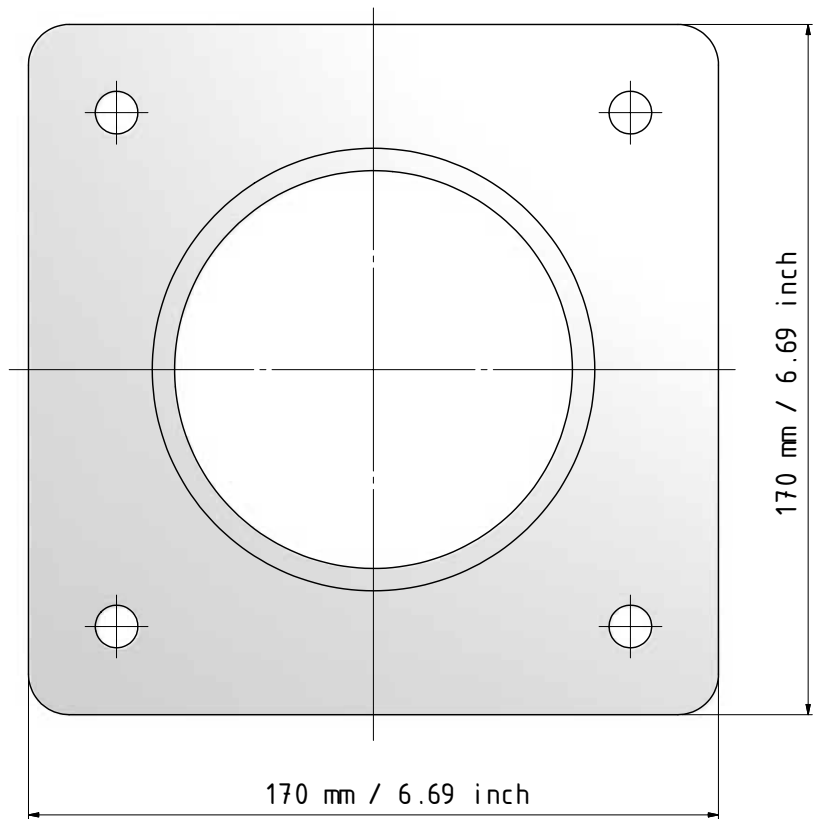
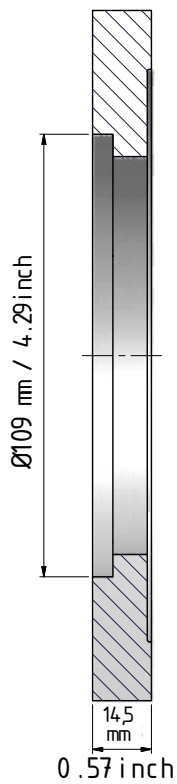

**Code No. 1310-1**

**4" / DN 100 4" Welding flange W Ø114 mm, Steel**

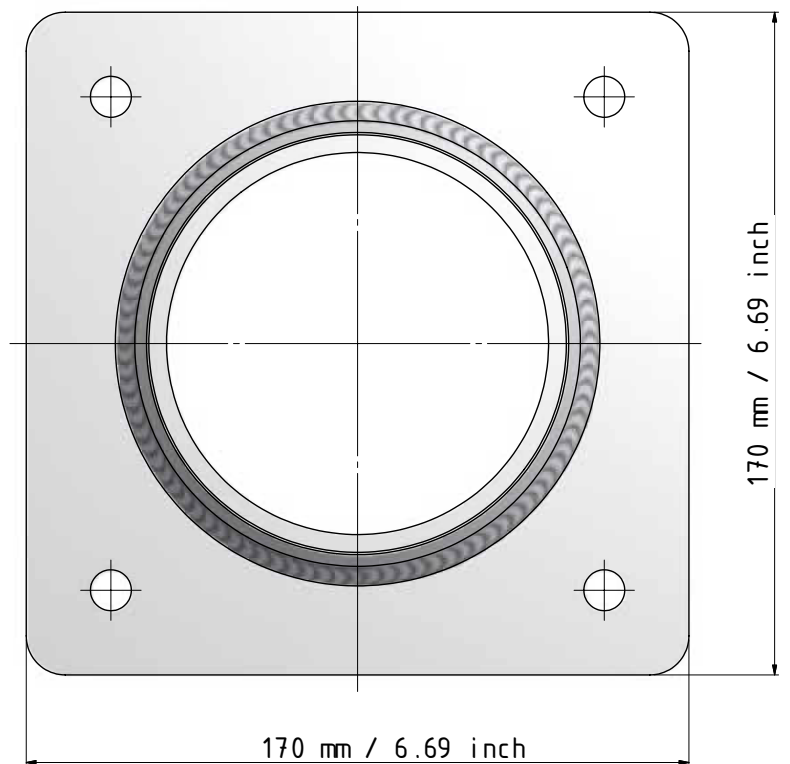
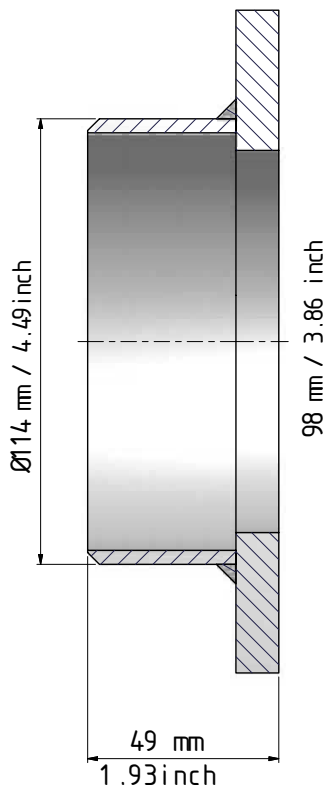

**Code No. 1364-3**

**4" / DN 100 4" Welding flange W Ø114 mm, Steel**

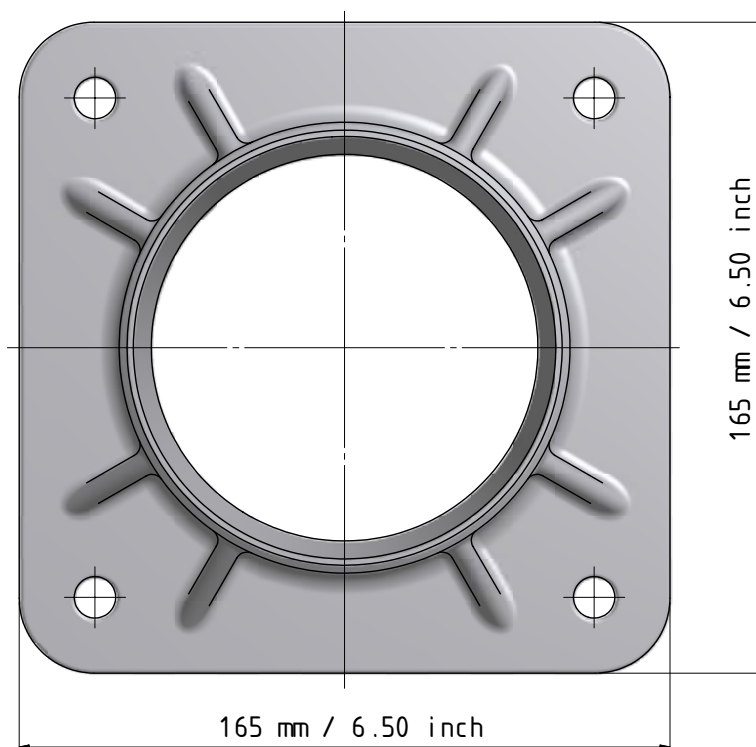
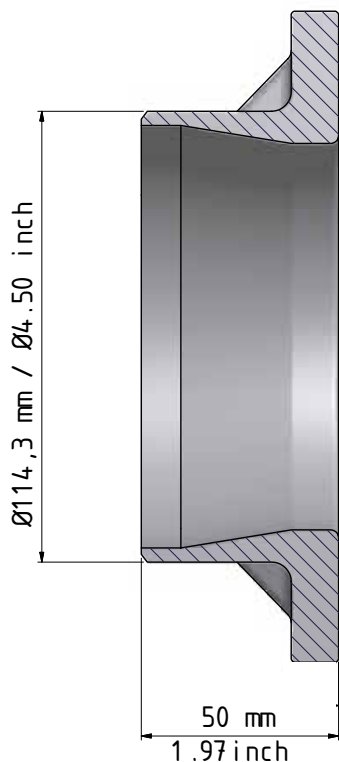

**Code No. 1364-3G**

**4" / DN 100 4" Welding flange W Ø114 mm, Stainless Steel**

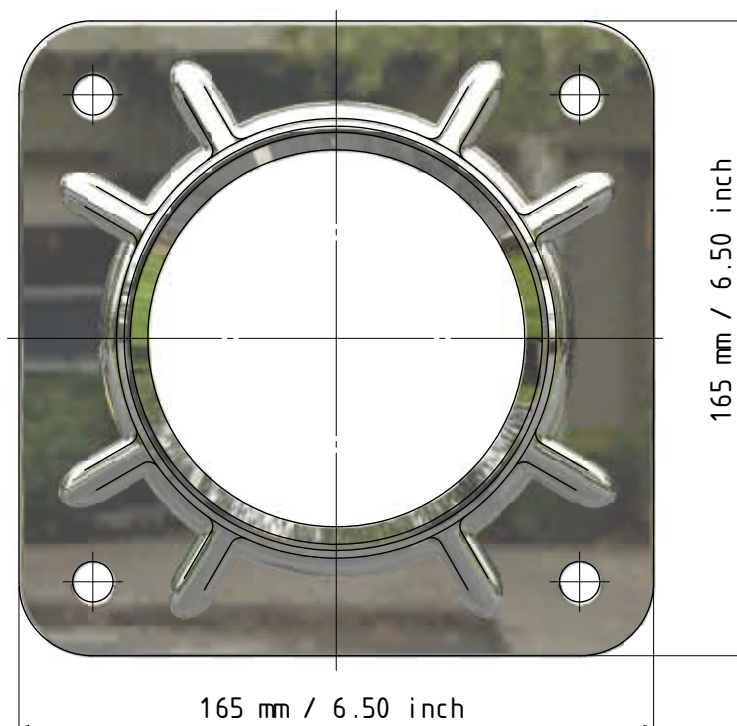
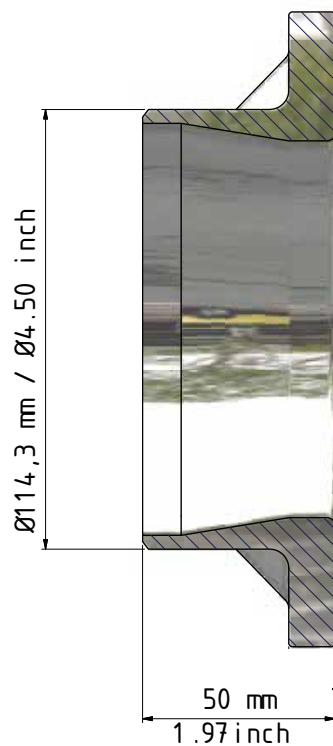

**Code No. 1364-4G**

**4" / DN 100 4" Victualic ANSI AWWA C-606**

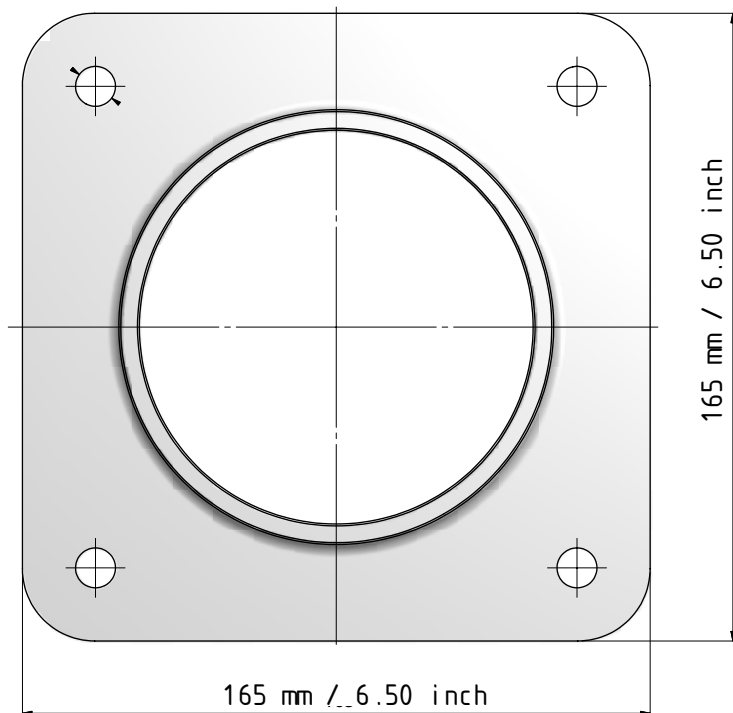
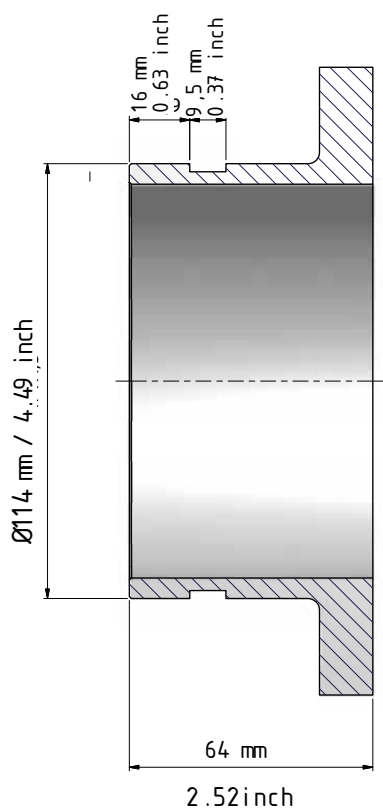

**Code No. 2198-1**

## Flange Measurement

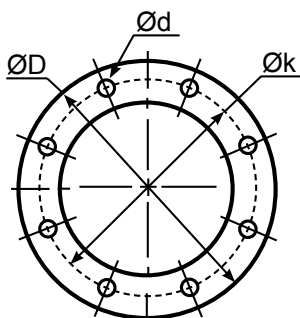

$\varnothing D$  = Diameter  
 $\varnothing k$  = Centre diameter  
 $n$  = Numer of holes  
 $\varnothing d$  = Hole diameter

EN 1092-1																	
DN	PN 10				PN 16				PN 25				PN 40				
		ØD	Øk	n	Ød	ØD	Øk	n	Ød	ØD	Øk	n	Ød	ØD	Øk	n	Ød
20	mm	105	75	4	14	105	75	4	14	105	75	4	14	105	75	4	14
	inch	4.13	2.95		0.55	4.13	2.95		0.55	4.13	2.95		0.55	4.13	2.95		0.55
25	mm	115	85	4	14	115	85	4	14	115	85	4	14	115	85	4	14
	inch	4.53	3.35		0.55	4.53	3.35		0.55	4.53	3.35		0.55	4.53	3.35		0.55
32	mm	140	100	4	18	140	100	4	18	140	100	4	18	140	100	4	18
	inch	5.51	3.94		0.71	5.51	3.94		0.71	5.51	3.94		0.71	5.51	3.94		0.71
40	mm	150	110	4	18	150	110	4	18	150	110	4	18	150	110	4	18
	inch	5.91	4.33		0.71	5.91	4.33		0.71	5.91	4.33		0.71	5.91	4.33		0.71
50	mm	165	125	4	18	165	125	4	18	165	125	4	18	165	125	4	18
	inch	6.50	4.92		0.71	6.50	4.92		0.71	6.50	4.92		0.71	6.50	4.92		0.71
65	mm	185	145	4	18	185	145	4	18	185	145	8	18	185	145	8	18
	inch	7.28	5.71		0.71	7.28	5.71		0.71	7.28	5.71		0.71	7.28	5.71		0.71
80	mm	200	160	8	18	200	160	8	18	200	160	8	18	200	160	8	18
	inch	7.87	6.30		0.71	7.87	6.30		0.71	7.87	6.30		0.71	7.87	6.30		0.71
100	mm	220	180	8	18	220	180	8	18	235	190	8	22	235	190	8	22
	inch	8.66	7.09		0.71	8.66	7.09		0.71	9.25	7.48		0.87	9.25	7.48		0.87
125	mm	250	210	8	18	250	210	8	18	270	220	8	26	270	220	8	26
	inch	9.84	8.27		0.71	9.84	8.27		0.71	10.63	8.66		1.02	10.63	8.66		1.02
150	mm	285	240	8	22	285	240	8	22	300	250	8	26	300	250	8	26
	inch	11.22	9.45		0.87	11.22	9.45		0.87	11.81	9.84		1.02	11.81	9.84		1.02
200	mm	340	295	8	22	340	295	12	22	360	310	12	26	375	320	12	30
	inch	13.39	11.61		0.87	13.39	11.61		0.87	14.17	12.20		1.02	14.76	12.60		1.18
250	mm	395	355	12	22	405	355	12	26	425	370	12	30	450	385	12	33
	inch	15.55	13.98		0.87	15.94	13.98		1.02	16.73	14.57		1.18	17.72	15.16		1.30
300	mm	445	400	12	22	460	410	12	26	485	430	16	30	515	450	16	33
	inch	17.52	15.75		0.87	18.11	16.14		1.02	19.09	16.93		1.18	20.28	17.65		1.30

## Flange translation EN 1092 ---- DIN

EN 1092-1	DIN
EN 1092-1 PN 6	DIN 2631
EN 1092-1 PN 10	DIN 2632
EN 1092-1 PN 16	DIN 2633
EN 1092-1 PN 25	DIN 2634
EN 1092-1 PN 40	DIN 2635
EN 1092-1 Type B Raised Face	DIN 2526 Form C
EN 1092-1 Type C Tongue	DIN 2512 Form F
EN 1092-1 Type D Groove	DIN 2512 Form N
EN 1092-1 Type E Spigot	DIN 2513 Form V
EN 1092-1 Type F Recess	DIN 2513 Form R



## Flange Measurement

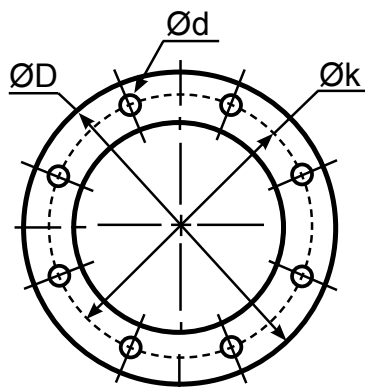

- Ø D = Diameter
- Ø k = Centre diameter
- n = Numer of holes
- Ø d = Hole diameter

ANSI B 16,5										
DN		150 psi				300 psi				INCH
		ØD	Øk	n	Ød	ØD	Øk	n	Ød	
19	mm	98	70	4	16	117	82	4	19	3/4"
	inch	3.86	2.76	0.16	0.63	4.61	3.23	0.16	0.75	
25	mm	108	79	4	16	124	89	4	19	1"
	inch	4.25	3.11	0.16	0.63	4.88	3.50	0.16	0.75	
32	mm	117	89	4	16	133	98	4	19	1 1/4"
	inch	4.61	3.50	0.16	0.63	5.24	3.86	0.16	0.75	
40	mm	127	98	4	16	156	114	4	22	1 1/2"
	inch	5.00	3.86	0.16	0.63	6.14	4.49	0.16	0.87	
50	mm	152	121	4	19	165	127	8	19	2"
	inch	5.98	4.76	0.16	0.75	6.50	5.00	0.31	0.75	
65	mm	178	140	4	19	190	149	8	22	2 1/2"
	inch	7.01	5.51	0.16	0.75	7.48	5.87	0.31	0.87	
80	mm	190	152	4	19	209	168	8	22	3"
	inch	7.48	5.98	0.16	0.75	8.23	6.61	0.31	0.87	
100	mm	229	190	8	19	254	200	8	22	4"
	inch	9.02	7.48	0.31	0.75	10.00	7.87	0.31	0.87	
125	mm	254	216	8	22	279	235	8	22	5"
	inch	10.00	8.50	0.31	0.87	10.98	9.25	0.31	0.87	
150	mm	279	241	8	22	317	270	12	22	6"
	inch	10.98	9.41	0.31	0.87	12.48	10.63	0.47	0.87	
200	mm	343	298	8	22	381	330	12	25	6"
	inch	13.50	11.73	0.31	0.87	15.00	12.99	0.47	0.98	

T.T.M.A						
DN		ØD	Øk	n	Ød	INCH
50	mm	114,3	95,3	6	11,1	2"
	inch	4.50	3.75	0.24	0.44	
80	mm	142,9	123,8	8	11,1	3"
	inch	5.63	4.87	0.31	0.44	
100	mm	168,3	149,2	8	11,1	4"
	inch	6.63	5.87	0.31	0.44	
125	mm	196,9	177,8	12	11,1	5"
	inch	7.75	7.00	0.47	0.44	
150	mm	228,6	206,4	12	11,1	6"
	inch	9.00	8.13	0.47	0.44	
200	mm	276,2	257,2	16	11,1	8"
	inch	10.87	10.13	0.63	0.44	

TW DIN 28459						
	DN		ØD	Øk	n	Ød
TW1	80	mm	154	130	8	11
		inch	6.06	5.12	0.31	0.43
TW3	100	mm	174	150	8	14
		inch	6.85	5.91	0.31	0.55
TW5	125	mm	204	176	8	14
		inch	8.03	6.93	0.31	0.55
TW7	150	mm	240	210	12	14
		inch	9.45	8.27	0.47	0.55

**Pressure Drop Measurement**

**Pressure Drop Measurement**  
According to NATO STANAG 3756, Annex E

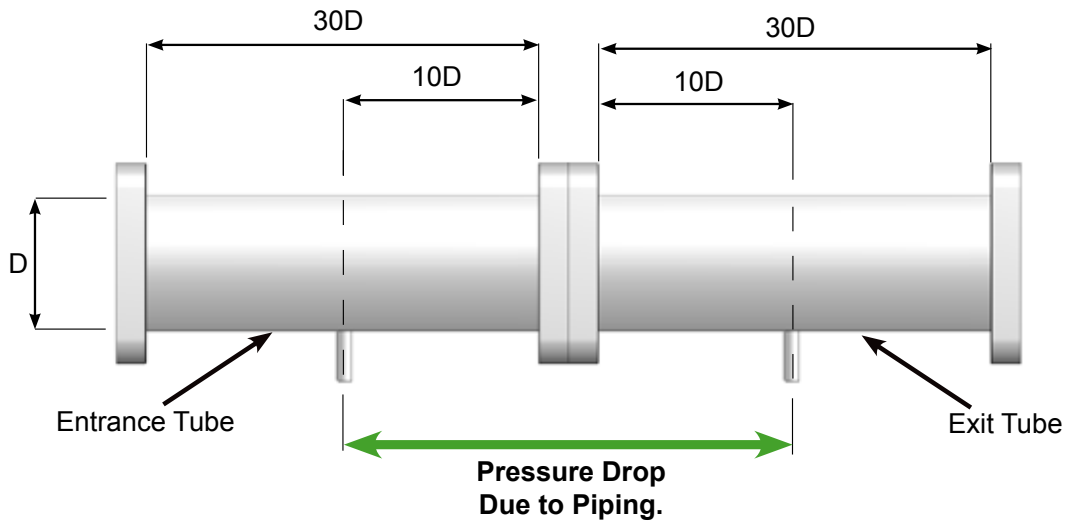
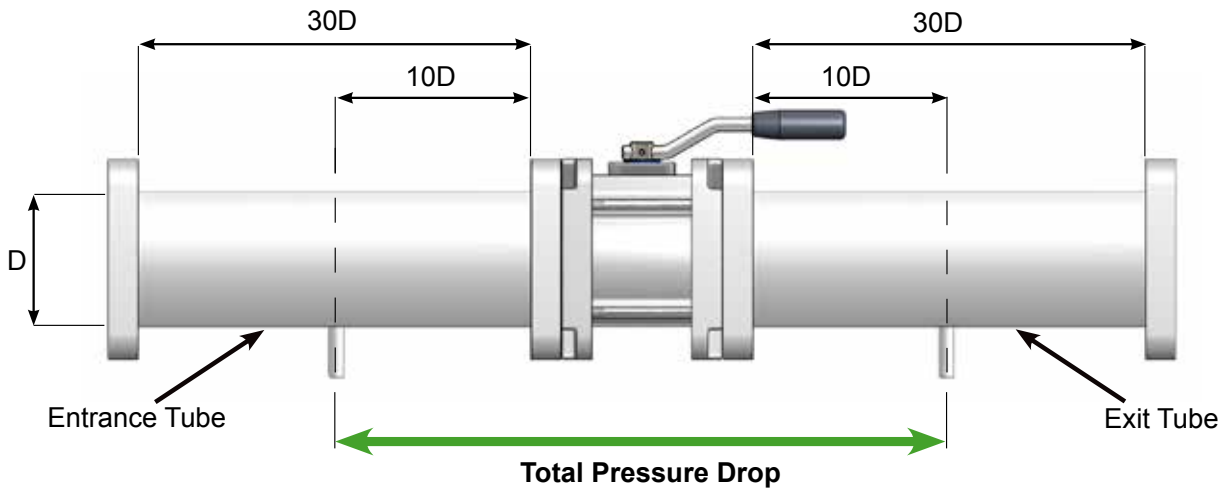

**Pressure Drop Ball Valve = Total Pressure Drop - Pressure Drop Due to Piping**

Pressure Drop Ball Valve =  $\Delta P$

## Flow Diagram - Pressure Drop for Ball Valves

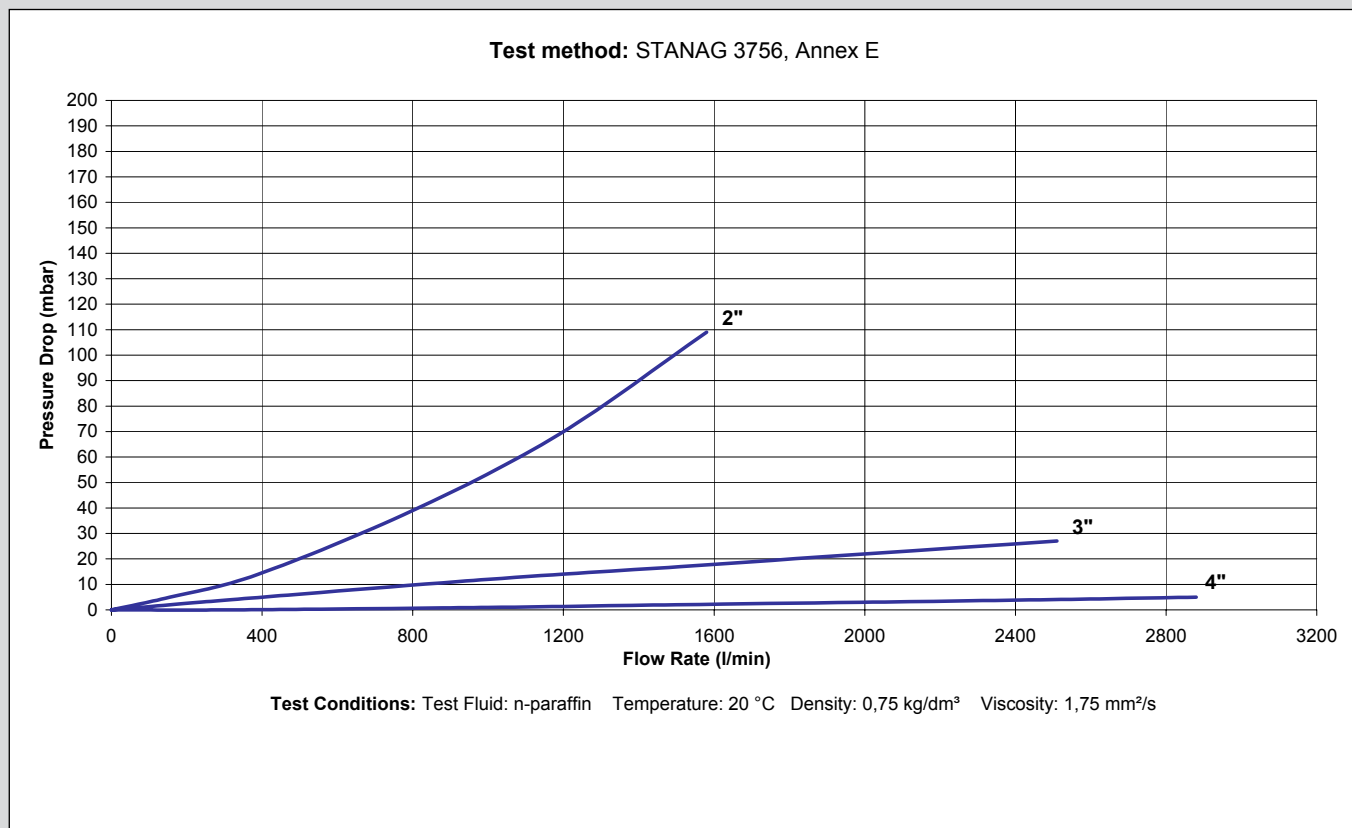

## Flow Diagram - Pressure Drop for 2-way Valves

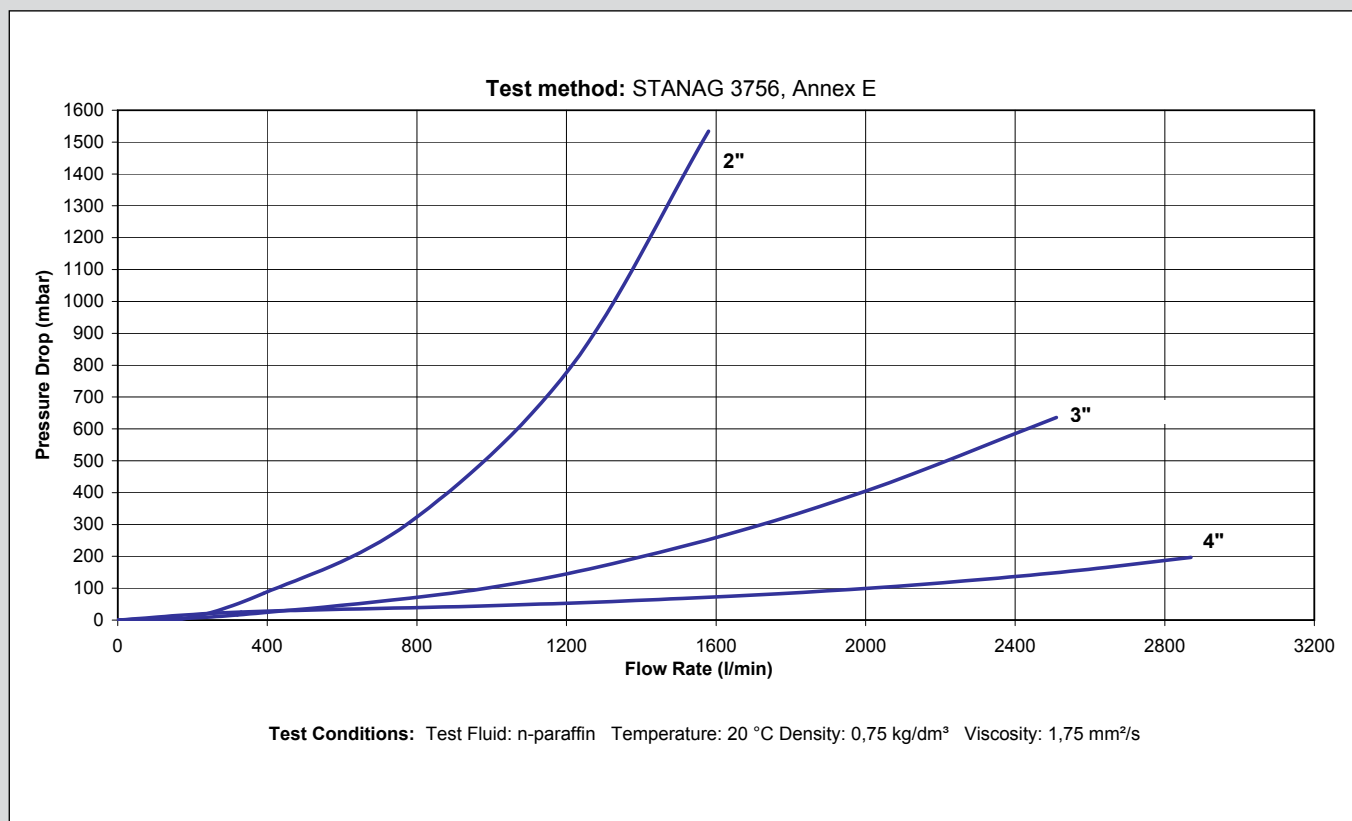

## Efficient design pneumatic actuators

WM pneumatic actuators are designed according to Euro-standards DIN/ISO 5211 and Namur/VDI/VDE 3845. The actuator design has following features: Piston gear teeth are equipped with a support bar which rolls against the relief in the shaft. This relieves the load on the teeth, makes smooth travel and

increases life of actuator. As a result of our patented design of return springs, single acting actuators have the same dimensions as double acting. WM-actuators have 93 degrees travel with end stop adjustment, in order to compensate eventual play in valve shaft and coupling

**Support bar – rolling track for the shaft relief**

**Hard sliding pads of POM for low friction**

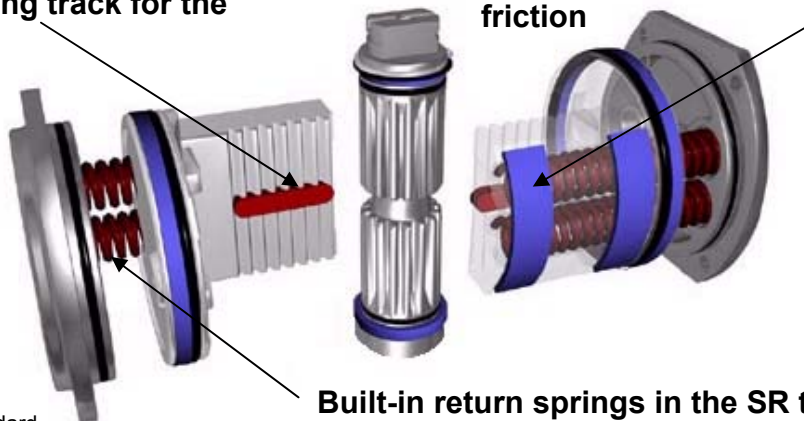

- ✓ DIN/ISO/NAMUR-standard
- ✓ Gear teeth relieved of load
- ✓ Built-in return springs

**Built-in return springs in the SR type**

### Double-acting type DA

### Single-acting type SR with Return springs

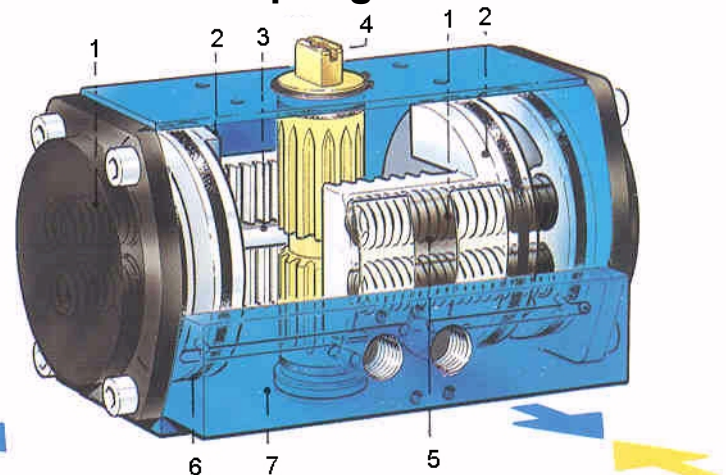
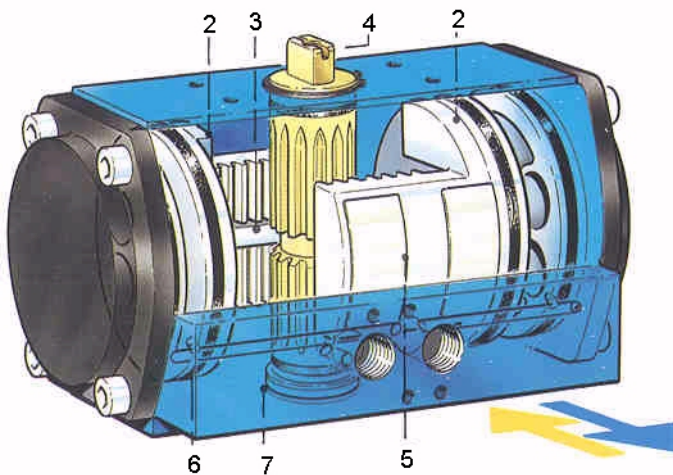

1. Return spring
2. Piston
3. Support bar
4. Shaft

5. Sliding pad
6. O-ring
7. Air connections

ATEX approved



## Operation actuators

WM actuators have a linear torque characteristic. The torque is constant throughout the angle of rotation (Double act.). This makes sizing of actuators easy.

WM actuators can easily be modified from DA to SR simply, by removing end caps fit the springs into the spring wells and refitting the end caps.

The direction of rotation can be altered easy by just turning the pistons. SR actuators can be used either to close or open the valve in the event of loss of air supply.

Adjustable end stop in outer position is standard.

WM actuators are permanently greased and need not normally be connected to a mist lubricator.

### Double-acting type DA

Anti-clockwise - opens

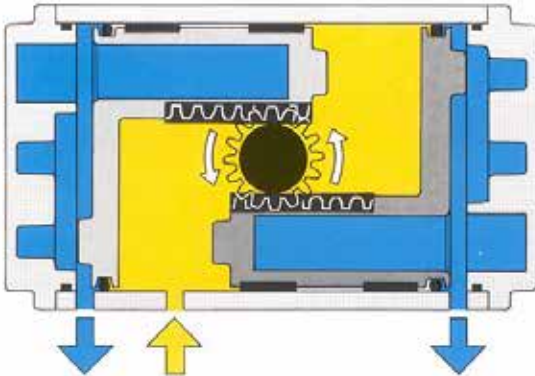

Clockwise - closes

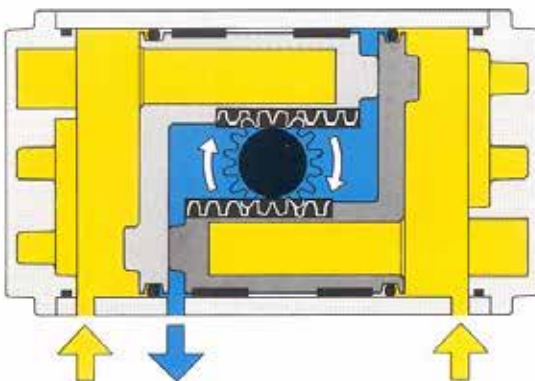

 Air in

### Single-acting type SR with return springs

Anti-clockwise - opens

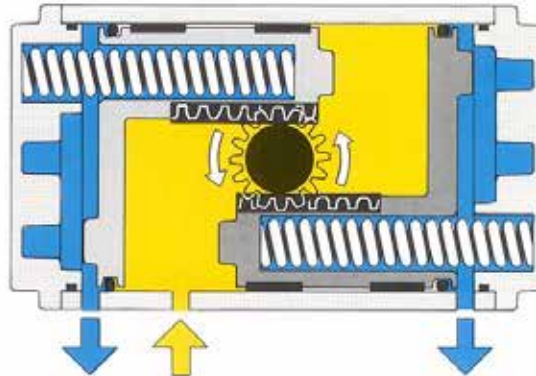

Clockwise - closes

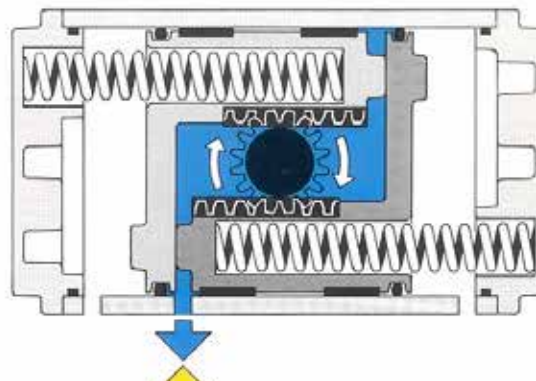

 Air out

ATEX approved





## Technical specification pneumatic actuators

Wire Matic is a Swedish produced rack and pinion actuator which gives a linear torque over the angle of rotation. WM actuators can easily be modified from double acting (DA) to single acting (SR) with spring return by fitting a spring kit. WM actuators are used for on-off and control valves. Standard blue anodized or ChemicalNickel impregnated (CNI) + PTFE treatment for corrosive environments.

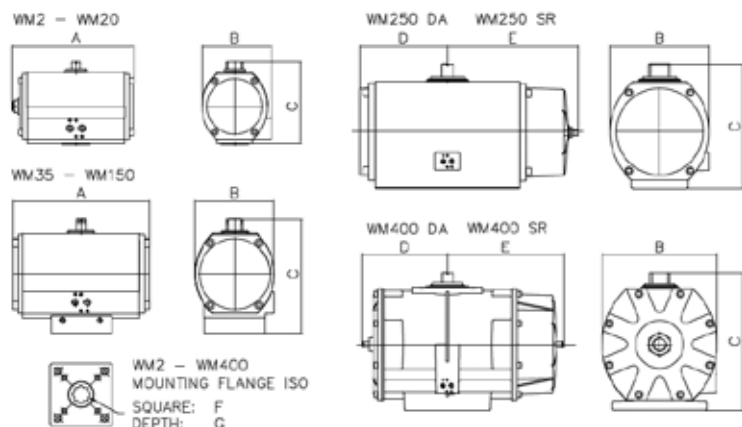

Type	DA Torque Nm@ 5.5bar	DA Actuator Varenr:	DA Weight Kg.	A mm.	B mm.	C mm.	D mm.	E mm.	F mm.	G mm.	ISO 5211	SR Torque Nm@ 5.5bar	SR Spring kit Varenr:	SR Weight Kg.	DA/SR Seal kit Varenr:
WM 2	21	xxxxxxxx	1.0	125	76	93	-	-	11	15	F04	6/9	xxxxxxxx	1.1	xxxxxxxx
WM 4	41	xxxxxxxx	1.7	147	88	111	-	-	11	15	F05	13/16	xxxxxxxx	1.9	xxxxxxxx
WM 8	75	xxxxxxxx	2.8	186	105	129	-	-	14	18	F05/F07	25/27	xxxxxxxx	3.2	xxxxxxxx
WM 12	122	xxxxxxxx	4.0	218	120	139	-	-	14	18	F05/F07	37/37	xxxxxxxx	4.6	xxxxxxxx
WM 12	122	xxxxxxxx	4.0	218	120	139	-	-	17	21	F05/F07	37/37	xxxxxxxx	4.6	xxxxxxxx
WM 20	206	xxxxxxxx	6.3	238	137	161	-	-	17	21	F07	67/71	xxxxxxxx	7.2	xxxxxxxx
WM 35	375	xxxxxxxx	10.1	270	156	226	-	-	22	54	F10	122/169	xxxxxxxx	11.8	xxxxxxxx
WM 55	595	xxxxxxxx	18.0	312	194	273	-	-	27	49	F10/F12	194/216	xxxxxxxx	21.1	xxxxxxxx
WM 70	727	xxxxxxxx	20.3	358	198	277	-	-	27	59	F10/F12	243/239	xxxxxxxx	23.0	xxxxxxxx
WM 100	1140	xxxxxxxx	25.6	366	229	333	-	-	36	62	F14	379/554	xxxxxxxx	32.1	xxxxxxxx
WM 150	1680	xxxxxxxx	33.0	394	280	381	-	-	36	65	F14	720/691	xxxxxxxx	45.0	xxxxxxxx
WM 250	2697	xxxxxxxx	58.0	-	280	352	249	369	46	50	F16	1042/1121	xxxxxxxx	82.0	xxxxxxxx
WM 400	4543	xxxxxxxx	115.0	-	360	435	268	364	55	58	F25	2207/1409	xxxxxxxx	140.0	xxxxxxxx

### Specifications:

Cylinder & end caps	Aluminium, Anodized
Shaft	Steel, plated
Adjustment screw & bolts:	Stainless steel
Air supply WM 2-8	Namur 1/8"
Air supply WM 12-400	Namur 1/4"
Mounting flanges	ISO
Max pressure	10 bar

### Option:

Corrosion resistant (CNI) actuators
Solenoid valve Joucomatic 24V DC
Solenoid valve Joucomatic 230V AC
Limit switch box ITS-100
Limit switch box Eex"d" ITS-300
Positioner PMV D3 (In 4-20mA/out 4-20mA)

### Varenr.

Contact
xxxxxxxx
xxxxxxxx
xxxxxxxx
xxxxxxxx
xxxxxxxx

ATEX approved



## Technical specification pneumatic actuators

Actuating medium: Compressed air or nitrogen  
 Max pressure: 10 bar  
 Actuating air demand/5,5 bar: 52 to 17.500 cm<sup>3</sup> – see tabled below  
 Temperature limits: -30° to +80°

### Double-acting type DA

Actuator designation		Torque Nm	Air consumption cm <sup>3</sup>		Displacement cm <sup>3</sup>	Actuator time* sec		Weight Kg
			Clockwise	Anti-clockwise		Opening	Closing	
WM 2	DA	21	96	125	120	<1	<1	1
WM 4	DA	41	184	236	240	<1	<1	1,7
WM 8	DA	75	340	430	430	<1	<1	2,8
WM 12	DA	122	486	636	700	1-1,5	1-1,5	4
WM 20	DA	206	900	994	1180	1-2	1-2	6,3
WM 35	DA	375	1694	1900	2180	1,5-2,5	1,5-2,5	10,1
WM 55	DA	595	2800	3400	3560	2-4	2-4	18
WM 70	DA	727	3050	3700	4160	2-4	2-4	20,3
WM 100	DA	1140	5518	5900	6520	3-4,5	3-4,5	25,6
WM 150	DA	1680	7600	9600	9620	3,5-5	3,5-5	33
WM 250	DA	2697	8500	9800	16258	4-7	4-7	58
WM 400	DA	4543	13600	17500	27392	8-12	8-12	115

\* The times are dependent on the size of solenoid valve used for the air supply

### Single-acting SR with return springs

Actuator designation		Torque Nm				Air consumption cm <sup>3</sup> Anti-clockwise	Displacement cm <sup>3</sup>	Actuator time* seconds		Weight Kg
		Anti-clockwise with air at		Clockwise with & spring at				air Opening	spring Closing	
		0°	90°	0°	90°					
WM 2	SR	15	9	12	6	125	120	<1	<1	1,1
WM 4	SR	27	16	25	13	236	240	<1	<1	1,9
WM 8	SR	47	25	49	27	408	430	<1	<1	3,2
WM 12	SR	84	37	84	37	636	700	1-1,5	0,5-1	4,6
WM 20	SR	138	71	134	67	994	1180	1-2	1-1,5	7,2
WM 35	SR	251	169	204	122	1900	2180	1,5-2,5	1-2	11,8
WM 55	SR	402	216	308	194	3400	3560	2-4	1,5-3	21,1
WM 70	SR	484	239	488	243	3700	4160	2-4	1,5-3	23
WM 100	SR	758	554	583	379	5900	6520	3,5-5,5	2-3	32,1
WM 150	SR	963	691	992	720	9600	9620	4,5-7	2,5-4	45
WM 250	SR	1655	1121	1576	1046	9800	16258	5-8	3-5	82
WM 400	SR	2517	1409	3134	2026	17500	27392	10-13	8-10	140

\* The times are dependent on the size of solenoid valve used for the air supply

ATEX approved



## Accessories - pneumatic actuators

### SOLENOID VALVE JOUCOMATIC NAMUR 5/2 - 3/2

#### Multi function 3/2 or 5/2 for SR/DA-actuators

The solenoid valve is delivered with two different namurplates. One for 3/2- ways and one for 5/2- ways. The valve is directly mounted on a WM-actuator



#### Solenoid Valve designation:

Solenoid Valve Namur 3/2

Solenoid Valve Namur 5/2

#### Specifications:

<b>Body:</b>	Aluminium, anodized
<b>Pressure:</b>	2 – 10 Bar
<b>Enclosure:</b>	IP 65
<b>Temperature:</b>	-25°C - +60°C
<b>Coils:</b>	12, 24, 48, 110 and 230V AC/DC
<b>Connector:</b>	mPm-Connector, PG11
<b>Operators:</b>	Pilot: Solenoid, air Return: Spring
<b>Air inlets:</b>	BSP 1/4"
<b>Options:</b>	Ex-coil Double pulse coil Connector with LED varistor Connector with cable Silencer/Speed control

#### Namur connection

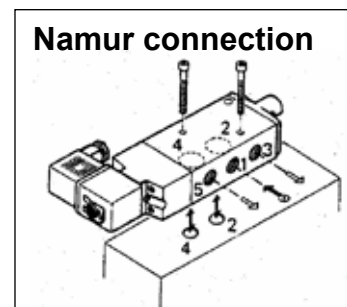

ATEX approved



# Accessories - pneumatic actuators

## LIMIT SWITCH BOX WM-ITS100



### Specifications:

- Body:** Aluminium, epoxy – powder coated
- Enclosure:** IP 67 CE- Marked
- Shaft:** Stainless steel
- Bracket:** Stainless steel
- Switch cams:** Adjustable, preset for 90°
- Cable inlets:** 2x M20
- Terminal block:** Plastic, 8 -ways
- Mechanical switches:** 2 pcs. Max 250V AC 16A, 125 V DC 0.6A

**Limit Switch Box designation:**  
Switch Box WM-ITS 100

### Alternative Switches

- Proximity sensors:** 2 pcs. type V3, IFM IS 5001, 10-36V DC PNP
- Proximity sensors:** 2 pcs type V3, IFM NS 5002, 5-25V DC Namur

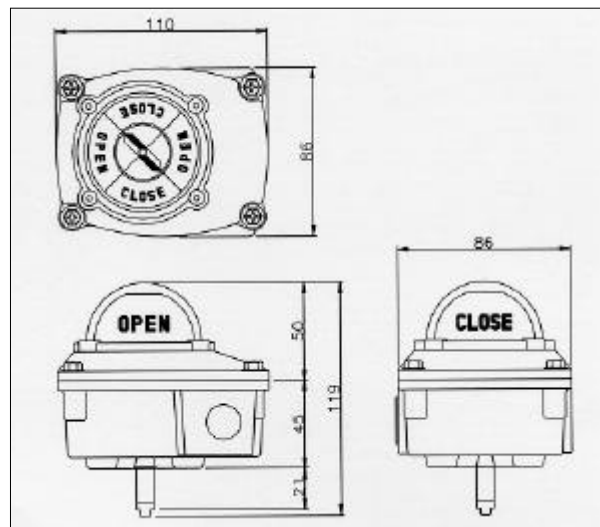
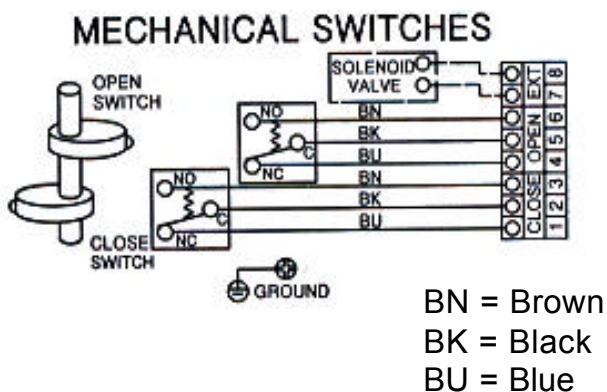



**II 2 GD Ex d IIB T6**  
**tD A21 IP67 T80°C**  
**CE 0081 LCIE 06 ATEX 6006X**

**Pour actionneurs 400V et option EBS.24 /**  
*For 400V actuators with EBS.24 / Für 400V Stellantriebe und mit EBS.24 :*

**II 2 GD Ex d IIB T5**  
**tD A21 IP67 T95°C**



## Electric Actuators - Mechanical mounting

### DIMENSIONS OF THE ACTUATOR

- The actuator is set to its closed position in our factory.
- Possible fixations : F05 (4xM6 with  $\varnothing 50$ ) and F07 (4xM8 with  $\varnothing 70$ ), star 17, depth 19mm.
- Do not mount the actuator « upside down ».
- Necessary height above the valve for the mounting of the actuator : H=300mm.

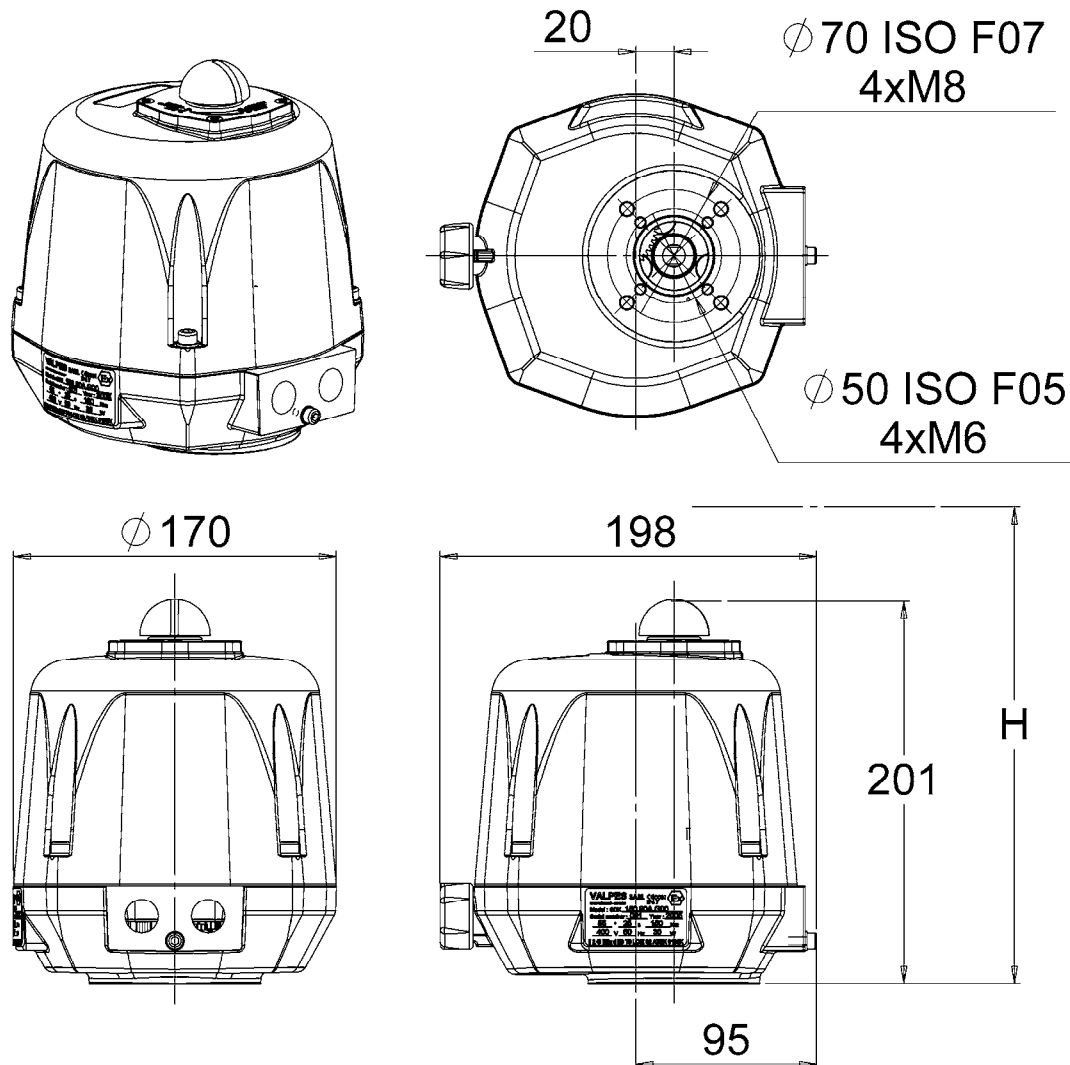

### EMERGENCY MANUAL OVERRIDE

In case of an electric supply failure, it is possible to operate the actuator manually :

- Turn the knob (appendix p.14 mark 9) to position MAN and hold it in position.
- Turn the outgoing drive shaft of the actuator with the help of an adjusting spanner.
- In order to re-engage the reduction, release the knob.

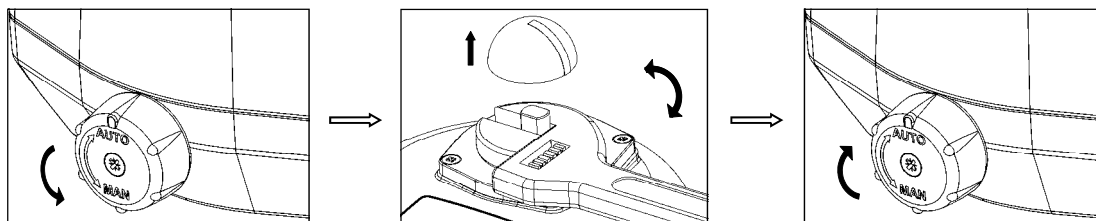

### MOUNTING / DISASSEMBLY OF THE COVER AND POSITION INDICATOR

For the wiring and setting of the actuator, it is necessary to remove the cover.

- Mounting of the cover (appendix p.14 mark 2) : make sure that the seal ring (appendix p.14 mark 7) is correctly placed in its position, grease of the flame path (Molydal 3790 grease or equivalent), mount the cover and tighten the 4 screws M6 (appendix p.14 mark 3, torque : 6Nm).
- Mounting of the position indicator (appendix p.14 mark 1) : fit the indicator onto the outgoing axle.

## Electric Actuators - Electric Connection

The caps placed on M20x1.5 threaded openings (appendix p.14 mark 15) must be replaced by ATEX certified connection glands.

- Remove the position indicator, unscrew the four screws and take off the cover.



**RESPECT SAFETY INSTRUCTIONS**

### SUPPLY AND CONTROL WIRING

- Ensure that the voltage indicated on the actuator ID label (appendix p.14 mark 11) corresponds to the voltage supply.
- Connect to earth through the exterior bolt M5 located under the cable gland (appendix p.14 mark 16). It is also possible to connect the actuator to earth inside the actuator through the bolt M3 next to the terminal strip (appendix p.15 mark A).
- Unscrew the left cable gland and insert the cable.
- Connect the wires to the terminal strip (appendix p.15 mark B) in accordance with the required control mode.

3-points modulating mode

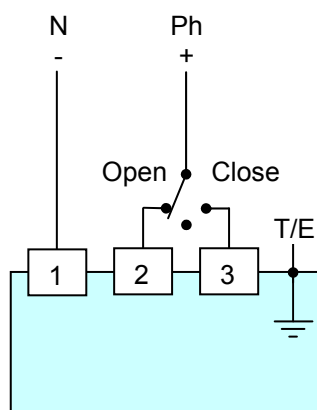

On-Off mode (pre-set to closed)

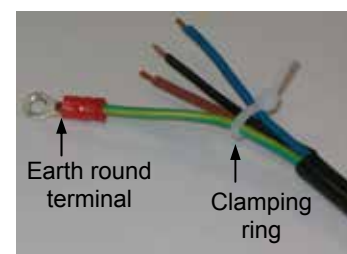
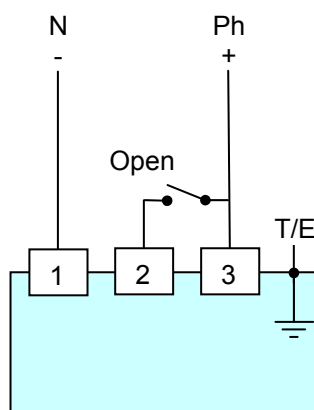

- Put a lacing cord around the wires (see the picture beside) and re-tighten the cable gland.

### WIRING OF THE FEEDBACK SIGNAL

Our actuators are equipped with two simple limit switch contacts normally set in their open position (NO). As per factory setting, the white cam is used to detect the open position (FC1) and the black cam is used to detect the closed position (FC2). This feedback system accepts voltages between 24V and 240V AC/DC.

- Unscrew the right cable gland and insert the cable.
- Remove 25mm of the cable sheath and strip each wire by 8mm.
- Connect the wires to the terminal strip (appendix p.14 mark 12) in accordance with the diagram beside.
- Tighten the cable gland.

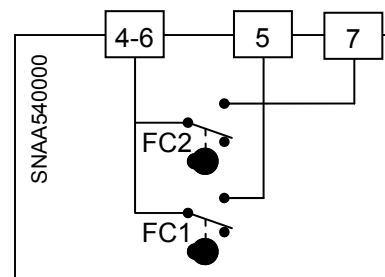

### SETTING OF END LIMIT SWITCHES

The actuator is pre-set in our factory. Do not touch the two lower cams in order to avoid any malfunctioning or even damage to the actuator.

- To adjust the position of the auxiliary contacts, make rotate the two superior cams by using the appropriate wrench.

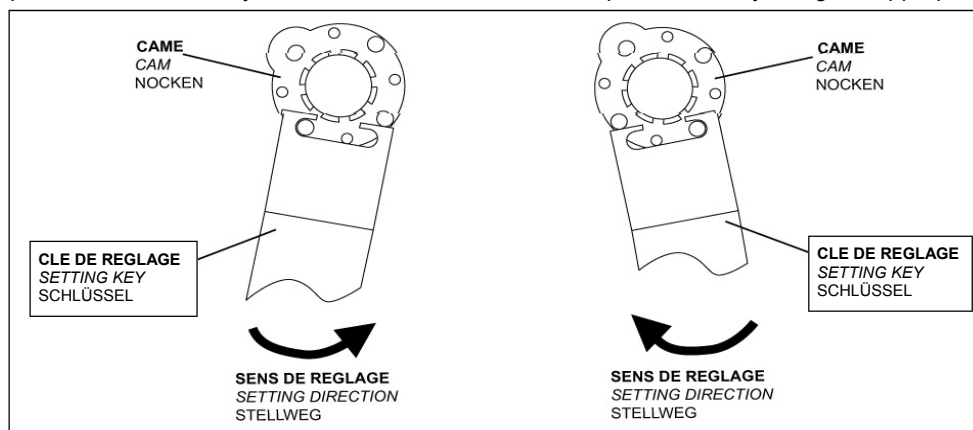

- Re-mount the cover, fasten the four screws and attach the position indicator.

## Electric Actuators - Instructions

### DESCRIPTION

The electric actuators VALPES have been designed to perform the control of a valve with 90° rotation. Please consult us for any different application. Valpes cannot be held responsible if the mentioned actuators are used in contradiction to this advice.

### SAFETY INSTRUCTIONS



**To be read prior to the installation of the product**

- The electric power supply must be switched-off before any intervention on the electric actuator (i.e. prior demounting its cover or manipulating the manual override knob). Wait 30 minutes before opening the cover.
- Any intervention must only be carried out by a qualified electrician or other person instructed in accordance with the regulations of electric engineering, safety, and all other applicable directives.
- Strictly observe the wiring and set-up instructions as described in the manual: otherwise, the proper working of the actuator can not be guaranteed anymore. Verify that the indications given on the identification label of the actuator fully correspond to the characteristics of the electric supply.
- The product must be protected by an easily accessible electric safety device (power isolator) corresponding to its power.
- As stipulated in the applicable regulation, the connection to earth contact is compulsory for devices with working voltages exceeding 42 V.

- Used symbols :



Danger : risk of electric shock



Earth protection



Direct and alternating voltage

- **The caps placed on M20x1.5 threaded openings must be replaced by ATEX certified connection glands.**

### TRANSPORT AND STORAGE

- The forwarding agents being held as responsible for damages and delays of the delivered goods, the consignees are obliged to express if applicable their reserves, prior to accept the goods. The goods delivered directly ex works are subject to the same conditions.
- The transport to the place of destination is carried out by using rigid packing material.
- The products must be stored in clean, dry, and ventilated places preferably on appropriate palettes or shelves.

### MAINTENANCE

- Maintenance is ensured by our factory. If the supplied unit does not work, please check the wiring according to the electric diagram as well as the power supply of the concerned electric actuator.
- For any question, please contact our after-sales service by phone 0033-476350606 or by email : [info@valpes.com](mailto:info@valpes.com).
- To clean the external elements of the unit, please use a wet rag.

### GUARANTEE

- 100% of the actuators are fully tested and set in the factory.
- The VALPES products are guaranteed two years from the delivery date or 50,000 operating cycles against all types of manufacturing and material faults (operating time and model class according to standard CEI34).
- This guarantee will only be valid if the unit has not been disassembled or self-repaired during its service life. It does not cover any wear and damage caused by shocks or faulty operation neither by the use of the unit under conditions not in accordance with its nominal characteristics. The guarantee is strictly limited to the replacement of original parts found defective on checking by our service personnel. The cost of shipping to our premises, the return of devices to the customer as well as the repair cost will be chargeable. We will not assume the responsibility for any direct or indirect accidents/risks originated by a failure of our products. The guarantee does not cover the consequences of breakdown and excludes any payments for indemnities. The accessories and adaptations are excluded from the guarantee. In the case where a customer has not proceeded to payments within the agreed period, our guarantee will be suspended until the delayed payments have been received and with the consequence that this suspension will not prolong the guarantee period in any case.

### RETURN OF GOODS

- The customer is obliged to check the conformity of the goods with regard to their definition at the time of delivery.
- The acceptance of the goods by the purchaser disclaims the supplier of all responsibility if the purchaser discovers any non-conformity after the date of acceptance. In such case, the repair cost will be borne by the purchaser who will also exclusively bear all financial consequences of any resulting damage. Returned goods will only be accepted if our prior agreement has been given to this procedure: the goods must be sent free of all cost and being shipped solely and in their original packing. The returned goods will be credited to the purchaser with a reduction of 20% on the unit's price charged in accordance with the original invoice of the returned goods.

- Do not mount the actuator « upside down ».  
- Do not mount the actuator less than 30 cm of an electromagnetic disturbances source.

## Flat Seals for thread

weight ≈kg	Thread BSP	Materials Application	Dimensions ≈ mm			Product No
			D	d	s	
0,001	BSP 1/2"	PTFE ( Teflon®) white , massive continuously hard, universally resistant  Teflon® is a registered trademark of DuPont	20	13	2	On request
0,001	BSP 3/4"		26	19	2	1498-06
0,002	BSP 1"		33	24	2	1220-06
0,003	BSP 1 1/4"		42	34	2	1536-06
0,003	BSP 1 1/2"		48	39	2	1196-06
0,004	BSP 2"		60	49	2	1052-06
0,007	BSP 2 1/2"		76	63	2,5	1181-06
0,006	BSP 3"		88	77	3	1110-06
0,009	BSP 4"		114	100	3	1295-06
0,016	BSP 6"		164	150	3	1963-06
0,001	BSP 1/2"	Thermopac asbestos free, light hard. Especially for hot oils and hot bitumen up to 250° C and for hot water and saturated steam up to 25 bar.	20	13	2	On request
0,001	BSP 3/4"		26	19	2	1498-25
0,002	BSP 1"		33	24	2	1220-25
0,002	BSP 1 1/4"		42	34	2	1536-25
0,003	BSP 1 1/2"		48	39	2	1196-25
0,004	BSP 2"		60	49	2	1052-25
0,005	BSP 2 1/2"		76	63	3	1181-25
0,009	BSP 3"		88	77	3	1110-25
0,013	BSP 4"		114	100	3	1295-25
0,016	BSP 6"		164	150	3	1963-25
0,001	BSP 1/2"	FPM/FKM (Viton®) soft for aromatic hydrocarbons and hot oils.  Viton® is a registered trademark of DuPont	20	13	2	On request
0,001	BSP 3/4"		26	19	2	1498-01
0,002	BSP 1"		33	24	2	1220-01
0,002	BSP 1 1/4"		42	34	2	1536-01
0,003	BSP 1 1/2"		48	39	2	1196-01
0,004	BSP 2"		60	49	2	1052-01
0,006	BSP 2 1/2"		76	63	3	1181-01
0,008	BSP 3"		88	77	3	1110-01
0,014	BSP 4"		114	100	3	1295-01
0,016	BSP 6"		164	150	3	1963-01

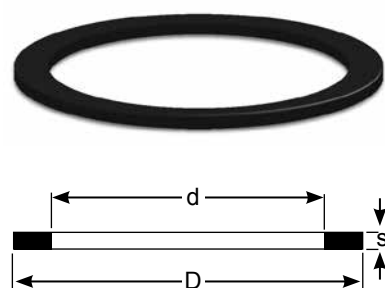
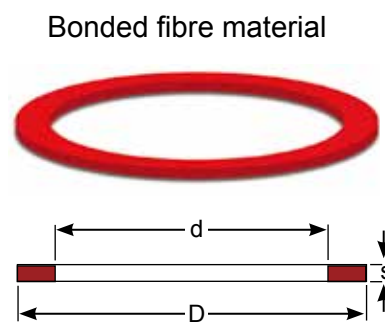
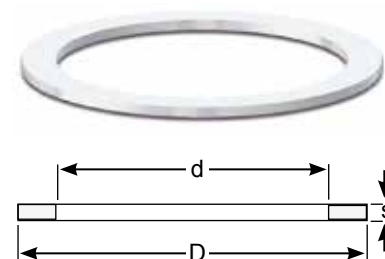

**Notice!** Seals are not included when you order flanges. You have to order Seals separately.

## Flat Seals for thread

Standard sizes of PUR (VULKOLLAN® polyurethane elastomer), injection molded. Colour:blue.Other sizes of PUR (VULKOLLAN® Cast polyurethane). Colour: honey-coloured. **Vulkollan®** is a registered trademark of Bayer



Weight Appr. ≈ Kg	Suitable for	Dimensions ≈ mm			Product No
		D	d	s	
0,001	BSP 3/4"	26	19	2	1498-09
0,001	BSP 1"	33	24	2	1220-09
0,001	BSP 1 1/4" (DN 25 + DN 32)	42	34	2	1536-09
0,002	BSP 1 1/2" (DN 32 + DN 38)	48	39	2	1196-09
0,003	BSP 1 3/4"	54	44	2,5	On request
0,003	BSP 2"	60	49	2	1052-09
0,005	BSP 2 1/2"	76	63	2,5	1181-09
0,006	BSP 3"	88	77	3	1110-09
0,010	BSP 3 1/2"	100	80	3	On request
0,009	BSP 4"	114	100	3	1295-09
0,012	BSP 5" ( No standard)	140	124	3	On request
0,016	BSP 6"	164	150	3	1963-09

## ELAPAC Flange Seals FD, QFD

Flange Standard / Suitable for	Dimensions ≈ mm					Product No
	D	d	Øk	Øh	s	
DN 25 PN 10/16	108	78,5	91	4 x 6,5	2	-
DN 32 PN 10/16	140	43	100	4 x 18	2	-
DN 50 PN 6	140	61	110	4 x 15	2	-
DN 50 TW 1	154	50	130	8 x 12	2	-
DN 80 TW 1	154	90	130	8 x 12	2	-
DN 50 PN 10/16	165	61	125	4 x 18	2	-
DN 100 TW3	174	110	150	8 x 14	2	-
DN 65 PN 10/16	185	76	145	4 x 18	2	-
DN 80 PN 10/16	200	90	160	8 x 18	2	-
DN 125 TW5	204	135	176	8 x 14	2	-
DN 100 PN 10/16	220	115	180	8 x 18	2	-
DN 150 TW7	240	160	210	12 x 14	2	-
DN 125 PN 10/16	250	141	210	8 x 18	2	-
DN 150 PN 10/16	280	169	240	8 x 22	2	-
DN 200 PN 10	340	220	295	8 x 22	2	-
DN 200 PN 16	340	220	295	12 x 22	2	-

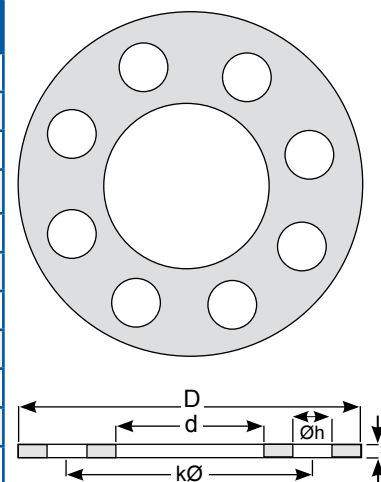

**Notice!** Seals are not included when you order flanges. You have to order Seals separately.



## About NPT and BSP threads

### NPT

**Sealing NPT threads can be an exasperating experience if certain techniques are not followed. The following tips will help alleviate many common problems in thread sealing:**

1. Always use some type of sealant (tape or paste) and apply sealant to male thread only. If using a hydraulic sealant, allow sufficient curing time before system is pressurized.

2. When using tape sealant, wrap the threads in a clockwise motion starting at the first thread and, as layers are applied, work towards the imperfect (vanishing) thread. If the system that the connection being made to cannot tolerate foreign matter (i.e. air systems), leave the first thread exposed and apply the tape sealant as outlined above.

3. When using paste sealant, apply to threads with a brush, using the brush to work the sealant into the threads. Apply enough sealant to fill in all the threads all the way around.

4. When connecting one stainless steel part to another stainless steel part that will require future disassembly, use a thread sealant that is designed for stainless steel. This stainless steel thread sealant is also useful when connecting aluminium to aluminium that needs to be disconnected in the future. These two materials gall easily, and if the correct sealant is not used, it can be next to impossible to disassemble.

5. When connecting parts made of dissimilar metals (i.e. steel and aluminium), standard tape or paste sealant performs satisfactory.

6. For sizes 2" and below, tape or paste performs satisfactory. When using thread tape, four wraps (covering all necessary threads) is usually sufficient.

7. For sizes 2½" and above, thread paste is recommended. If thread tape is used, eight wraps (covering all necessary threads) is usually sufficient. Apply more wraps if necessary.

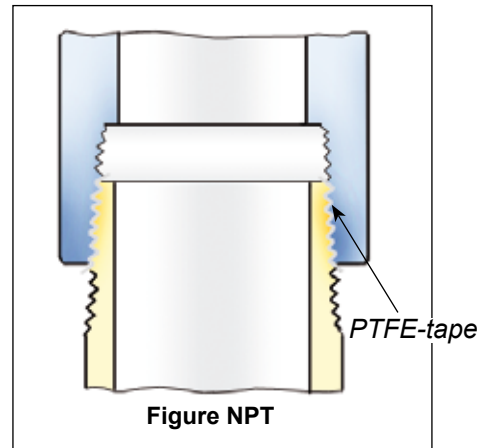

8. For stubborn to seal threads, apply a normal coating of thread paste followed by a normal layer of thread tape.

9. For extremely stubborn to seal threads, apply a normal coating of thread paste followed by a single layer of gauze bandage followed by a normal layer of thread tape.

#### Caution!

When this procedure is done, the connection becomes permanent. Extreme measures will be necessary to disconnect these components. All other measures to seal the threads should be explored prior to use of this technique.

10. Over-tightening threads can be just as detrimental as insufficient tightening. For sizes 2" and below, hand tighten the components and, with a wrench, tighten 3 full turns. For sizes 2½" and above, hand tighten the components and, with a wrench, tighten 2 full turns.

### BSP

**The threads are parallel with flat sealing surface.**

This allows to use the full thread length for screwed-on parts. The largest possible transfer of force is guaranteed for short length. The thread seal behind the relief groove of the thread cannot drop out.

Simple screwing down, makes a safe connection. Subsequent tightening during operation is possible at any time. Change of seal and new assembly do not require any expert knowledge.

The European standardisations for hose assemblies require parallel threads with flat seals, because of the advantages.

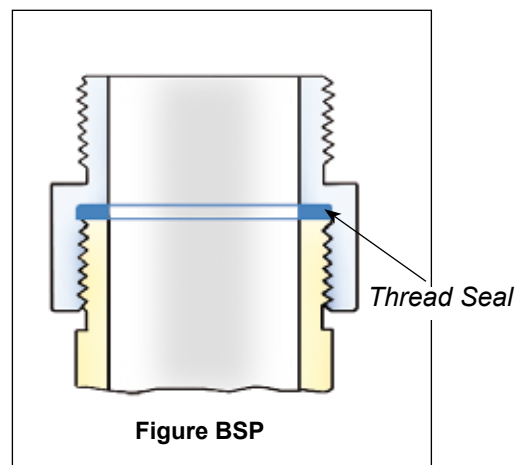

# Explanation of designations 1/2

**NOTE!** When swivels are chosen, the second and the third sign indicates one outlet, the fourth and the fifth sign the second outlet.

A = API-adapter  
 AV = Tank Unit (EN 13081)  
 B = Ball Valve  
 C = Dust Cap  
 CG = Dust Cap LPG  
 D = Swivel  
 E = Tank Unit with pressure valves  
 F = Hose Unit (ISO 45)  
 G = Tank Unit (ISO 45)  
 GS = Tank Unit (ISO 45) with selectivity  
 H = Sampling Vent & Drain Unit

I = Dust Plug ISO 45  
 K = Dust Cap ISO 45  
 L = Tank Unit LPG  
 LC = Tank Unit Cryogenic  
 M = Hose Unit LPG  
 MC = Hose Unit Cryogenic  
 N = Break Away Pin  
 NC = Break Away Pin Cryogenic  
 O = Break Away Wire  
 P = Dust Plug  
 R = Pressure Cap

RG = Pressure Cap LPG  
 S = Hose Unit (STANAG 3756)  
 SN = Hose Unit int. Break Away Pin  
 SO = Hose Unit int. Break Away Wire  
 T = Tank Unit (STANAG 3756)  
 TA = Tank Unit (ARTA Compatible)  
 TU = Tank Unit (Unleaded fuel)  
 U = Filter / Sight Glass  
 V = Dust Plug LPG  
 WA = Hose Fittings

## Second sign (numeral): Indicates the socket diameter and/or the nominal diameter

0 = 50mm or 3/4"  
 1 = 56mm or 1", 1 1/4"  
 2 = 70mm or 1 1/2", 2"  
 3 = 105mm or 2 1/2"

4 = 119mm or 3"  
 5 = 164mm or 4"  
 V = 5"  
 6 = 238mm or 6"

8 = 272mm or 8"  
 10 = 10"  
 12 = 12"

## Third and fourth sign (numeral): Indicates connection, (thread, flange etc.)

01 = 3/8" BSP (Female)  
 02 = 1/2" NPT (Female)  
 03 = 1" BSP (Female)  
 04 = 1" NPT (Female)  
 05 = 1 1/4" BSP (Female)  
 06 = 1 1/4" NPT (Female)  
 07 = 1 1/2" BSP (Female)  
 08 = 1 1/2" NPT (Female)  
 09 = 1 3/4" BSP (Female)  
 10 = 2" BSP (Female)  
 11 = 2" NPT (Female)  
 12 = 2 1/2" BSP (Female)  
 13 = 2 1/2" NPT (Female)  
 14 = 3" BSP (Female)  
 15 = 3" NPT (Female)  
 16 = 4" BSP (Female)  
 17 = 4" NPT (Female)  
 18 = Flange undrilled Ø156  
 19 = Flange undrilled Ø165  
 20 = Flange undrilled Ø210  
 21 = Flange undrilled Ø230  
 22 = Flange undrilled Ø254  
 23 = Flange DN 25 PN 10/16  
 24 = Flange DN 25 PN 25/40  
 25 = Flange DN 32 PN 10/16  
 26 = Flange DN 32 PN 25/40  
 27 = Flange DN 40 PN 10/16  
 28 = Flange DN 40 PN 25/40  
 29 = Flange DN 50 PN 25/40\*  
 30 = Flange DN 50 PN 10/16  
 31 = Flange DN 50 PN 25/40  
 32 = Flange DN 65 PN 25/40\*  
 33 = Flange DN 65 PN 10/16  
 34 = Flange DN 65 PN 25/40  
 35 = Flange DN 80 PN 25/40\*  
 36 = Flange DN 80 PN 10/16  
 37 = Flange DN 80 PN 25/40  
 38 = Flange DN 100 PN 25/40\*  
 39 = Flange DN 100 PN 10/16  
 40 = Flange DN 100 PN 25/40  
 41 = Flange DN 125 PN 6  
 42 = Flange DN 125 PN 10/16  
 43 = Flange DN 125 PN 25/40  
 44 = Flange DN 150 PN 6  
 45 = Flange DN 150 PN 10/16  
 46 = Flange DN 150 PN 25/40  
 47 = Flange DN 20 PN 10/16  
 48 = Flange DN 20 PN 25/40  
 49 = Flange 3/4" ANSI Class 150  
 50 = Flange 3/4" ANSI Class 300  
 51 = Flange 1" ANSI Class 150  
 52 = Flange 1" ANSI Class 300  
 53 = Flange 1 1/4" ANSI Class 150  
 54 = Flange 1 1/4" ANSI Class 300  
 55 = Flange 1 1/2" ANSI Class 150  
 56 = Flange 1 1/2" ANSI Class 300  
 57 = Flange 2" ANSI Class 150  
 58 = Flange 2" ANSI Class 300  
 59 = Flange 2 1/2" ANSI Class 150  
 60 = Flange 2 1/2" ANSI Class 300  
 61 = Flange 3" ANSI Class 150  
 62 = Flange 3" ANSI Class 300  
 63 = Flange 4" ANSI Class 150  
 64 = Flange 4" ANSI Class 300  
 65 = Flange TW 1 (3" - DN 80)  
 66 = Flange TW 3 (4" - DN 100)  
 67 = Flange 3" T.T.M.A.  
 68 = Flange 4" T.T.M.A.  
 69 = 3/8" BSP (Male)  
 70 = 1/2" NPT (Male)  
 71 = 1" BSP (Male)  
 72 = 1" NPT (Male)  
 73 = 1 1/4" BSP (Male)  
 74 = 1 1/4" NPT (Male)  
 75 = 1 1/2" BSP (Male)  
 76 = 1 1/2" NPT (Male)  
 77 = 1 3/4" BSP (Male)  
 78 = 2" BSP (Male)

79 = 2" NPT (Male)  
 80 = 2 1/2" BSP (Male)  
 81 = 2 1/2" NPT (Male)  
 82 = 3" BSP (Male)  
 83 = 3" NPT (Male)  
 84 = 4" BSP (Male)  
 85 = 4" NPT (Male)  
 86 = Weld.flange 2" Ø60,5 inner  
 87 = Flange TW 1 (2" - DN50)  
 88 = Weld.flange 2" Ø50-Ø70 (flat)  
 89 = Weld.flange 2" Ø57 (int. chamfer)  
 90 = Weld.flange 2" Ø60 (outer chamfer)  
 91 = Weld.flange 3" Ø75-Ø90 (flat)  
 92 = Weld.flange 3" Ø76 (int. chamfer)  
 93 = Weld.flange 3" Ø89 (outer. chamfer)  
 94 = Weld.flange 4" Ø100-Ø120 (flat)  
 95 = Weld.flange 4" Ø102 (int. chamfer)  
 96 = Weld.flange 4" Ø108 (int. chamfer)  
 97 = Weld.flange 4" Ø114 (outer. chamfer)  
 98 = Flange TW 1 (2" - DN 50) with drain connection  
 99 = Flange DN 150 PN 25  
 100 = Flange 6" ANSI Class 150  
 101 = Flange 6" ANSI Class 300  
 102 = Flange DN 200 PN 10  
 103 = Flange DN 200 PN 16  
 104 = Flange DN 200 PN 25  
 105 = Flange 8" ANSI Class 150  
 106 = Flange 8" ANSI Class 300  
 107 = Flange Square ISO 45  
 108 = S60x6 (Female)  
 109 = S60x6 (Male)  
 110 = 6" BSP (Female)  
 111 = 6" NPT (Female)  
 112 = W2" - 7 (Female)  
 113 = Weld.flange 3" Ø92 inner  
 114 = Square flange, 4 holes  
 115 = 6" BSP (Male)  
 116 = 6" NPT (Male)  
 117 = 8" NPT (Female)  
 118 = 4" Victaulic  
 119 = Flange DN 50 PN 25/40\*\*  
 120 = Flange DN 65 PN 25/40\*\*  
 121 = Flange DN 80 PN 25/40\*\*  
 122 = Flange DN 100 PN 25/40\*\*  
 123 = W2" - 7 (Male)  
 124 = 5" NPT (Female)  
 125 = 5" NPT (Male)  
 126 = Flange DN 100 PN6  
 127 = Flange DN 80 PN6  
 128 = Flange DN 65 PN6  
 129 = Flange DN 50 PN6  
 130 = Flange 8" ANSI Class 600  
 131 = W90x1/6" (Female)  
 132 = 1/2" NPT (Female)  
 133 = 1/2" BSP (Female)  
 134 = Flange Ø184.2, 6 holes  
 135 = Flange TW 7 (6" - DN 150)  
 136 = 4" ASSPT (Female)  
 137 = Triclamp DN 25  
 138 = M54x 1,5 (Female)  
 139 = 2" Triclamp (ISO 2852-51)  
 140 = Weld.flange Ø73 (outer chamfer)  
 141 = 3" Victaulic  
 142 = Flange 5" ANSI Class 150  
 143 = 3" Ball valve  
 144 = 2" Victaulic  
 145 = 3" BSPT (Male)  
 146 = 5" Victaulic  
 147 = 2" BSPT (Female)  
 148 = 2" BSPT (Male)  
 149 = 1 1/2" Victaulic  
 150 = 2 1/2" Victaulic  
 151 = Flange 1" DIN 11864-2  
 152 = Flange 2" DIN 11864-2  
 153 = Flange Ø135, 8xM6  
 154 = 4" BSPT (Female)  
 155 = 4" BSPT (Male)

156 = Weld flange 2" Ø61,5 (inner)  
 157 = 3" BSPT (Female)  
 158 = Weld end 1 1/2" Ø48 (outer)  
 159 = Thread TR 57x4  
 160 = Flange 2" BS10 Table D  
 161 = Flange 12" ANSI Class 150  
 162 = Flange 10" ANSI Class 150  
 163 = Flange DN 250 PN 16  
 164 = M130x6 (Female)  
 165 = Flange 10" ANSI Class 300  
 166 = ACME 1 1/4" (Female)  
 167 = ACME 1 1/4" (Male)  
 168 = ACME 2 1/4" (Female)  
 169 = ACME 3 1/4" (Female)  
 170 = ACME 1 1/4" (Male)  
 171 = ACME 1 1/4" (Male)  
 172 = ACME 2 1/4" (Male)  
 173 = ACME 3 1/4" (Male)  
 174 = Weld.flange Ø76 (outer. chamfer)  
 175 = Flange DN 15 PN 10/16  
 176 = Flange DN 15 PN 25/40  
 177 = M130x6 (Male)  
 178 = Flange 6" T.T.M.A.  
 179 = Flange DN 80 PN 25/40\*\*\*  
 180 = 1/2" NPT (Male)  
 181 = 1/2" BSP (Male)  
 182 = 5" BSP (Female)  
 183 = 5" BSP (Male)  
 184 = Weld end 8" Ø219 (outer)  
 185 = Weld end 6" Ø168 (outer)  
 186 = Flange DN 250 PN 25  
 187 = Flange 2" T.T.M.A.  
 188 = Flange 3" BS10 Table D  
 189 = Flange 1/2" ANSI Class 150  
 190 = Flange 1" ANSI Class 150 Flat Face  
 191 = Flange 12" ANSI Class 300  
 192 = Flange DN250 PN10  
 193 = Weld end Ø114 Schedule 40  
 194 = Weld end Ø114 Schedule 80  
 195 = 6" Victaulic  
 196 = 1" Victaulic  
 197 = Flange DN 125 JIS 5K  
 198 = Flange DN 100 JIS 5K  
 199 = Flange DN 80 JIS 5K  
 200 = Flange DN 50 JIS 5K  
 201 = Flange DN 40 JIS 5K  
 202 = Flange 2" DIN 11864-3  
 203 = 3/2" BSP (Female)  
 204 = Flange Ø110, Ø86/Ø5.5 (6x)  
 205 = Weld end Ø60 Schedule 80  
 206 = Weld end Ø89 Schedule 40  
 207 = Weld end Ø89 Schedule 80  
 208 = Flange DN 25 PN 6  
 209 = Flange DN 32 PN 6  
 210 = Flange DN 40 PN 6  
 211 = Flange DN 125 JIS 10K  
 212 = Flange DN 100 JIS 10K  
 213 = Flange DN 80 JIS 10K  
 214 = Flange DN 50 JIS 10K  
 215 = Flange DN 40 JIS 10K  
 216 = Flange DN 80, holes Ø14 (6x)  
 217 = Flange 5" ANSI Class 300  
 218 = 3" Triclamp (ISO 2852-76)  
 219 = Weld end Ø34 Schedule 40  
 220 = Flange DN 150 JIS 10K  
 221 = Flange Ø175, holes M10 (8x)  
 222 = Weld end Ø140 PN10/16  
 223 = Flange 2" ANSI Class 150 Flat Face  
 224 = Flange DN 200 JIS 10K  
 225 = Flange DN 32 PN10/16  
 226 = Flange 6" ANSI Class 600  
 227 = Flange DN 50 JIS 16K  
 228 = Flange DN 40 JIS 16K  
 229 = 8" NPT (Male)  
 230 = 1" EN 10226 Rp1 (1" BSPT Parallel)  
 231 = Flange DIN 86282 PN6 AW595  
 232 = Flange DN100 PN6 (8 x M16)

\* EN 1092-1:2001 Type E: Spigot

\*\* EN 1092-1:2001 Type F

\*\*\* EN 1092-1:2001 Type C

No part of this leaflet may be reproduced in any form or by any means without permission in writing from the publisher

## Explanation of designations 2/2

Ver 1312

### Fifth sign (letter): Indicates version

A = Version No.1 (Machined from bar)	G = Drain connection	N = Non Return Valve
B = Version No.2 (Casted)	H = Leaf spring lock	O = Slim version Break Away
C = Version No.3 (Kokill casted)	I = Bended Tank Unit Short (15°)	P = Pressure (Custom)
D = Sep. piston guide	J = Bended Tank Unit (15°)	S = Sight Glass
E = Injection moulded	K = Short Tank Unit/Swivel	T = Transparent
F = 6" Flange Hydrant	L = Long Tank Unit/Swivel	U = Stop before disconnected

### Sixth sign (numeral): Indicates material in the coupling body

1 = Aluminium	6 = Titan
2 = Brass	7 = Hastelloy
3 = Steel	8 = PVDF
4 = Stainless steel A4 (316)	9 = PEEK
5 = Stainless steel A2 (304)	K = Inconel

### Seventh sign (numeral): Indicates material in the innerparts or other components

1 = Aluminium	6 = Titan
2 = Brass	7 = Hastelloy
3 = Steel	8 = PVDF
4 = Stainless steel A4 (316)	9 = PEEK
5 = Stainless steel A2 (304)	K = Inconel

### Eight and Ninth sign (numeral): Indicates the O-ring material in the coupling

01 = Viton® (FPM/FKM)	16 = Hypalon® (CSM)	33 = EPDM 291
02 = Nitrile (NBR)	17 = Chemraz® 505 (FFKM)	34 = Kalrez® 0040
03 = EPDM	18 = Xyflour® 860 (AFKM)	37 = Chemraz® 510 (90 Shore)
04 = Kalrez® (FFKM)	19 = Zetpol® / Therban® (HNBR)	40 = FEP PTFE encapsulated Viton®
05 = NBR Low temp	20 = NBR 90 shore	47 = Chemraz 605 High Temp
06 = Teflon® (PTFE)	21 = Viton®-GF (Special Viton quality)	50 = Kalrez® (PFPM) 1050LF
07 = Neoprene® (CR)	22 = Composite	51 = Nylon® (PA)
08 = Silicone (VMQ)	23 = Viton® GFLT-S	61 = Viton® (FPM), FDA, USP C6 & ADI
09 = Vulkollan® (PUR)	24 = Viton® GLT	62 = Nitrile (NBR), FDA, USP C6 & ADI
10 = Butyl (IIR)	25 = Klingerit®	63 = EPDM, FDA, USP C6 & ADI
11 = Nitrile (Gasol NBR 70 K-6)	26 = POM	64 = Kalrez® (FFKM) 6230, FDA, USP C6 & ADI
12 = Perfluorelastomer (FFPM/FFKM)	27 = Epichlorhydrin (ECO)	66 = PTFE (Virgin), FDA
13 = PVC / NBR	28 = Viton® GFLT-S NMO	71 = FPM/FKM Low Temp
14 = Fluorsilicone rubber (FVMQ)	29 = FPM/FKM High Temp	75 = FEP Silicone, FDA, USP C6 & ADI
15 = FEP encapsulated silicone	31 = Viton® 90 Shore (FPM/FKM)	77 = Chemraz® SD517, FDA, USP C6 & ADI
		83 = EPDM BAM

### Tenth sign (letter): Used for extra

A = Flat seal, Teflon®(PTFE)	M = Modified Cam Curve	V = Locking house unit
B = Flat seal, Vulkollan®(PUR)	N = No Branding	W = Double ball race
C = 2-way Ball Valve	NA = No Actuator (Ball Valve)	X = Special surface treatment
D = Flat seal, Viton® (FPM)	P = Pressure Equalizing Valve	Z = Excentric tank unit
DA = Double Acting (Ball Valve)	Q = Reduced bore diameter	-RA = Racing
E = None projecting piston spindle	(Argus,Hydrant)	-LC = Locking Cap
F = Flange thickness acc. to standard	R = Hose unit with int. Break Away	-S = FEP O-ring in Hose Unit swivel
G = Hypalon	S = Single Argus valve (Hydrant)	-ST = Steam
H = Nitrile (NBR)	SR = Spring Return (Ball Valve)	-XL = Oversized swivel
I = Emco comp	T = TW-Flange extended circles	-45 = 45 Mesh
J = EPDM	U = Pressure Bleeding Valve 16 bar	-60 = 60 Mesh
K = Locked piston guide	U5 = Pressure Bleeding valve 5 bar	-10 = 100 Mesh
L = Locked thread	U20 = Pressure Bleeding valve 20 bar	

No part of this leaflet may be reproduced in any form or by any means without permission in writing from the publisher.

Design may change without notice

©Mann Technik 2013

Selection of registered trade names from Messrs BASF, Bayer AG, B.F. Goodrich, Chemische Werke Hüls, Daikin, Dow Company, DSM, Du Pont, DuPont Dow Elastomers, Esso Chemie, Hercules, Hoechst AG, Montedison, Monteflous, Nippon Zeon, Polysar LTD., Rhone Poulenc, 3 M Company, Wacker Chemie, Precision Polymer Engineering Ltd.

## How to Order Ball Valves / 2-Way Valves with different Flanges

### Ball Valve

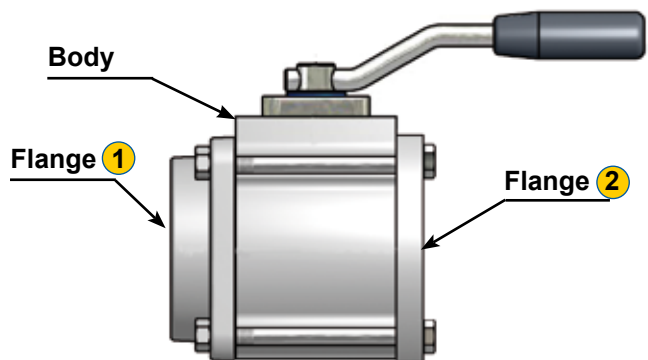

**Code No. Body + Flange 1 + Flange 2**

Bults, nuts and handle in Steel Zink plated. Stainless steel on request.

### 2-Way Valve

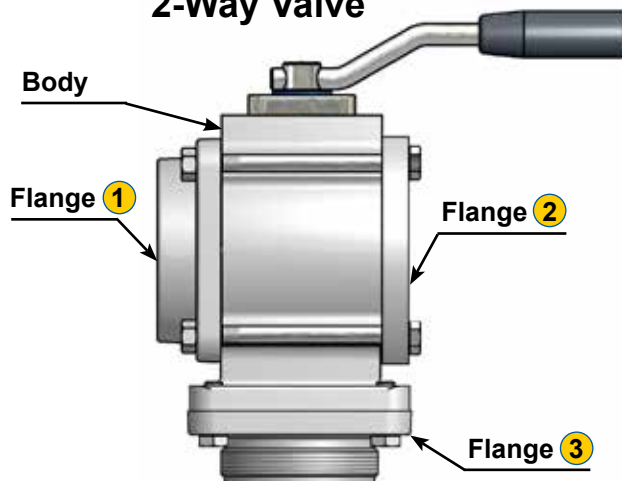

**Code No. Body + Flange 1 + Flange 2 + Flange 3**

Bults, nuts and handle in Steel Zink plated. Stainless steel on request.

## Questionnaire - Aluminium Ball Valves / 2-Way Valves

Date:	
Name:	Title:
Company:	Department:
Address:	Country:
Phone:	Fax:

### Produkt data / Produktdaten:

Code no.:	Quantity:
Ball Valve: <input type="checkbox"/>	2-way Ball Valve: <input type="checkbox"/>
Internal diameter :	Connection:
Material:	Requested delivery:
Other remarks:	

### Flow data:

Medium / Fluid (with chemical formulas/CAS no.):	Temp:
1)	
2)	
3)	
4)	
5)	
Working pressure :	Vaccum:

### Customers note:

--

## Maintenance and service instruction



Always depressurise the system and rinse off the parts before beginning any maintenance work. Use protective goggles. Do not handle O-ring seals if the material appears charred, gummy or sticky.



Use tweezers and wear neoprene or PVC gloves. Do not touch adjacent parts with unprotected hands. Rinse off the parts once again before starting the “daily inspection”

### Daily inspection:

- 1 Inspect the Ball-Valve surface for cleanliness and corrosion
- 2 Inspect the spindle and the spindle bushing that they are without leakage and fixed assembled
- 3 Inspect the Ball-Valve unit for faultlessness and external signs for leakage

Do not remove this tag until installation is approved by user

### Three-month inspection

1. Exterior cleaning of the Ball Valve with a neutral cleanser.
2. Careful “daily inspection” of cleaned units.

### Once a year

1. Exchange sealing and washer at least once a year.
2. Refill grease where needed
3. Replace worn or damaged components. Repair procedures are straightforward and no special tools are required.

Check the state of the connection surface and verify that it is clean before proceeding with the connection.

Check for correct operation of the valve. Switch the unit(s) several times.

Use only original Mann Technik spare parts for maintenance.

Support ring kit (S-BSRX-yy)

Handle kit (S-BSHX-yy)

X and yy means the size and the material key according to the product catalogue. You will find it also as the 2nd to 8th/9th sign in the serial number (eg. BX00A10yy).





## Repair service and certificate of decontamination

### REPAIR SERVICE

To comply with Health & Safety Regulations, all returned couplings and valves must be accompanied by a Certificate of Cleanliness and a Data Sheet for the last product carried (even the cleaner).

### CERTIFICATE OF DECONTAMINATION

We certify that the returned couplings/valves have been cleaned prior to despatch and are free of any harmful substances.

Quantity: \_\_\_\_\_

Code No: \_\_\_\_\_

Serial No: \_\_\_\_\_

Quantity: \_\_\_\_\_

Code No: \_\_\_\_\_

Serial No: \_\_\_\_\_

Quantity: \_\_\_\_\_

Code No: \_\_\_\_\_

Serial No: \_\_\_\_\_

Quantity: \_\_\_\_\_

Code No: \_\_\_\_\_

Serial No: \_\_\_\_\_

YES NO

Free of all liquid                    \_\_\_\_\_

Air blown                                \_\_\_\_\_

Coupling/Valve dismantled        \_\_\_\_\_

The last known product the coupling/valve was in contact with:

\_\_\_\_\_

Media Cast Number:

\_\_\_\_\_

Data sheet of last product attached (Yes/No):

\_\_\_\_\_

Company Name/Address:

\_\_\_\_\_

Signature of Supervisor:

\_\_\_\_\_

Company Stamp:









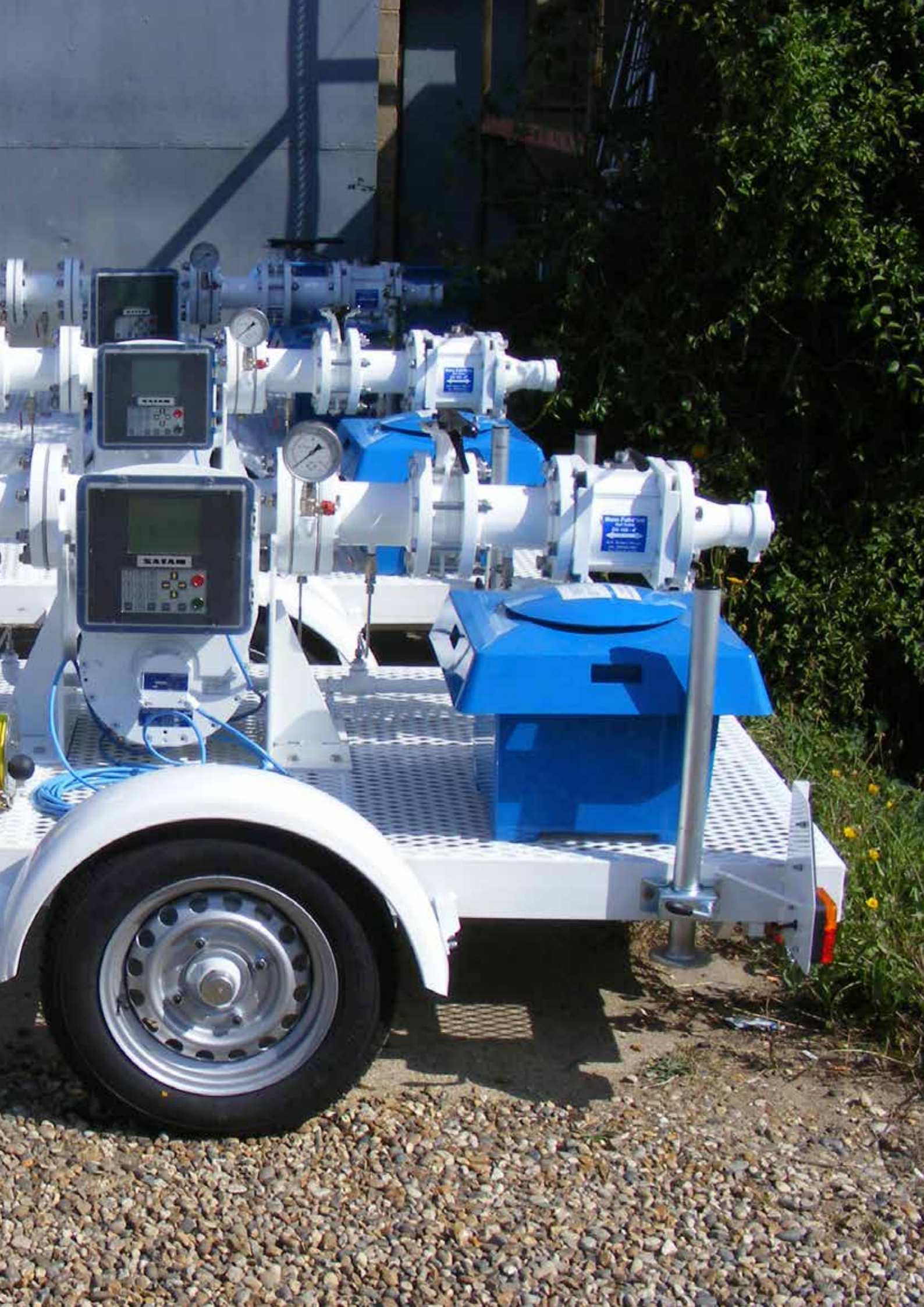



## Product Information



**DDCouplings®**  
Dry Disconnect Coupling.  
1" to 8", PN 16 - PN 25. Aluminium, Brass-Gunmetal, Stainless Steel and PEEK. Other materials on request. According to NATO standard STANAG 3756.



**DGCouplings®**  
Dry Gas Coupling.  
1" to 8", PN25. Stainless steel.  
Other materials on request.



**DACouplings,**  
Dry Aviation Coupling.  
2½", PN 10. Main body in Aluminium.  
**Standards:** ISO 45, MS 24484, NATO STANAG 3105, British Aerospace Spec. 2C14.

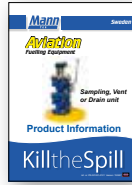

**Sampling, Vent or Drain unit**  
Stainless Steel SS-EN 10 088-1.4404+AT (AISI 316L). Ball Valve in 1.0619 and 1.4301



**Full Flow - ballvalves**  
2" to 4", PN 10, Aluminium.  
Ballvalve and 2-way Ballvalve.  
Made for Petroleum Tank Trucks. Variations of flange connections.



**Swivel joints**  
¾" to 10", PN 10 - PN 25.  
Aluminium, Brass-Gunmetal, Stainless Steel.  
Other materials on request.  
Connection: BSP, NPT. Flanged connection (DIN, ANSI/ASA e.t.c)



**SBCouplings, bolt series**  
**Industrial and Marine Safety Break-away, breaking bolts,**  
Aluminium, Brass, Stainless Steel, 1" to 12", female/male threads and with flanges, with breaking bolts.  
**Safety Break-away, cable release**  
Stainless Steel, PN10 / PN 25. 2" to 4", female threads. 6" to 12", flanged connection

## Business Segment Information



Offshore & Marine



Gas (LPG)



Rail tankers



Chemical industry



Tank trucks



Military



Container



Cryogenic Couplings

## Company Information



General Information about Mann Tek, products and Business Segments



Quality, Health, Safety and Environment Policy.  
Quality Approvals,  
Product Approvals and  
Declaration of Conformity



Service instructions and operation manuals

## Your distributor

Your distributor:

### Contact Mann Tek for your local distributor

**Phone:** +46 501 39 32 00  
**Fax:** +46 501 39 32 09  
**Email:** sales@mann-tek.com  
**Web site:** www.mann-tek.com

**Address:** Mann Teknik AB  
Strandvägen 16  
SE-542 31 Mariestad  
Sweden

