

YONGA TEKNOLOJİ & META

META REA DA MODEL ORANSAL ELEKTRİKLİ AKTÜATÖR ÜRÜN SUNUMU

META



*Presentation for
Actuator*

META

META



Why META

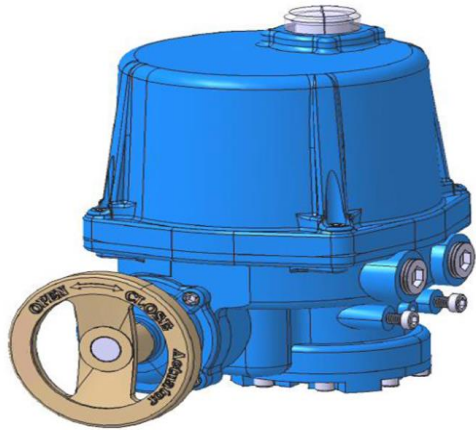



Because we have qualified
in **various industries**



- Gas and Oil
- Chemical plant
- Water treatment
- Air conditioning
- Ship building



Because **IP68** is a standard
48hours under 8m water





Because It's Time for Field bus

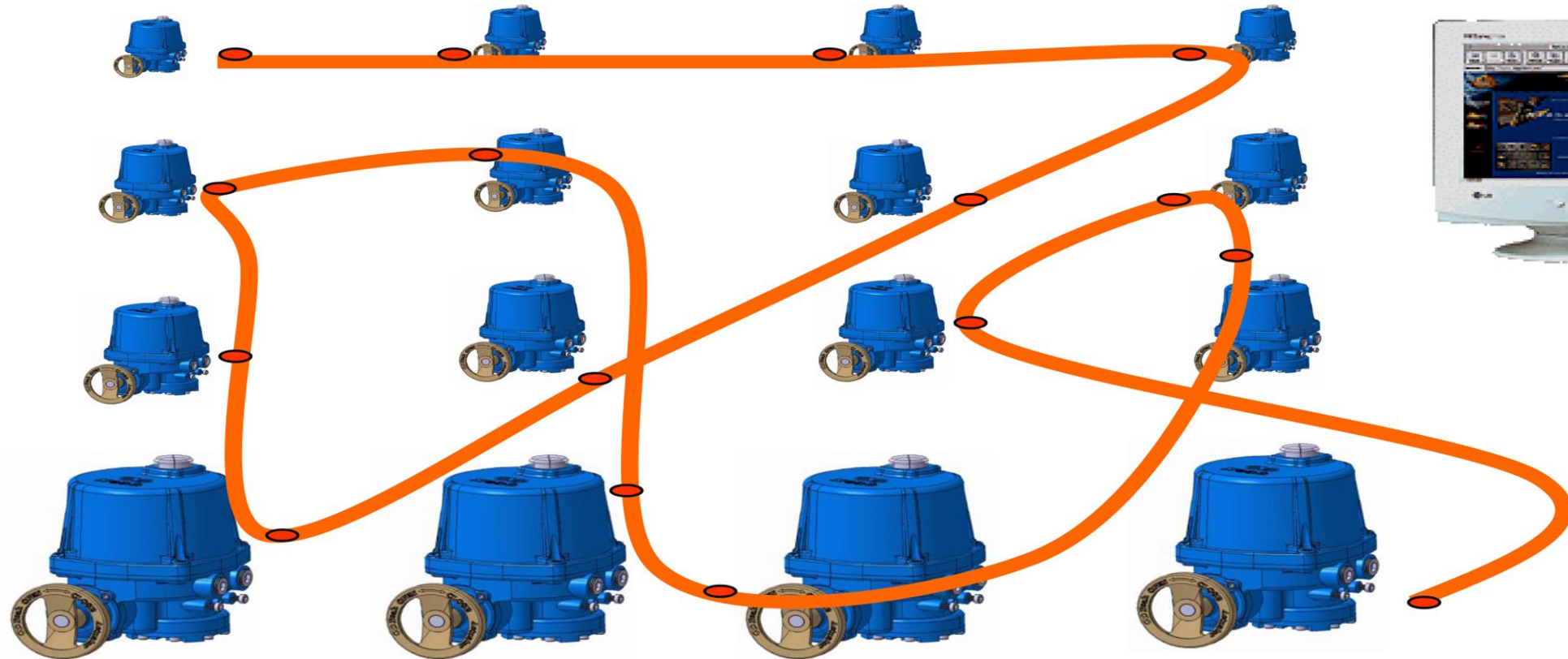



Configuration

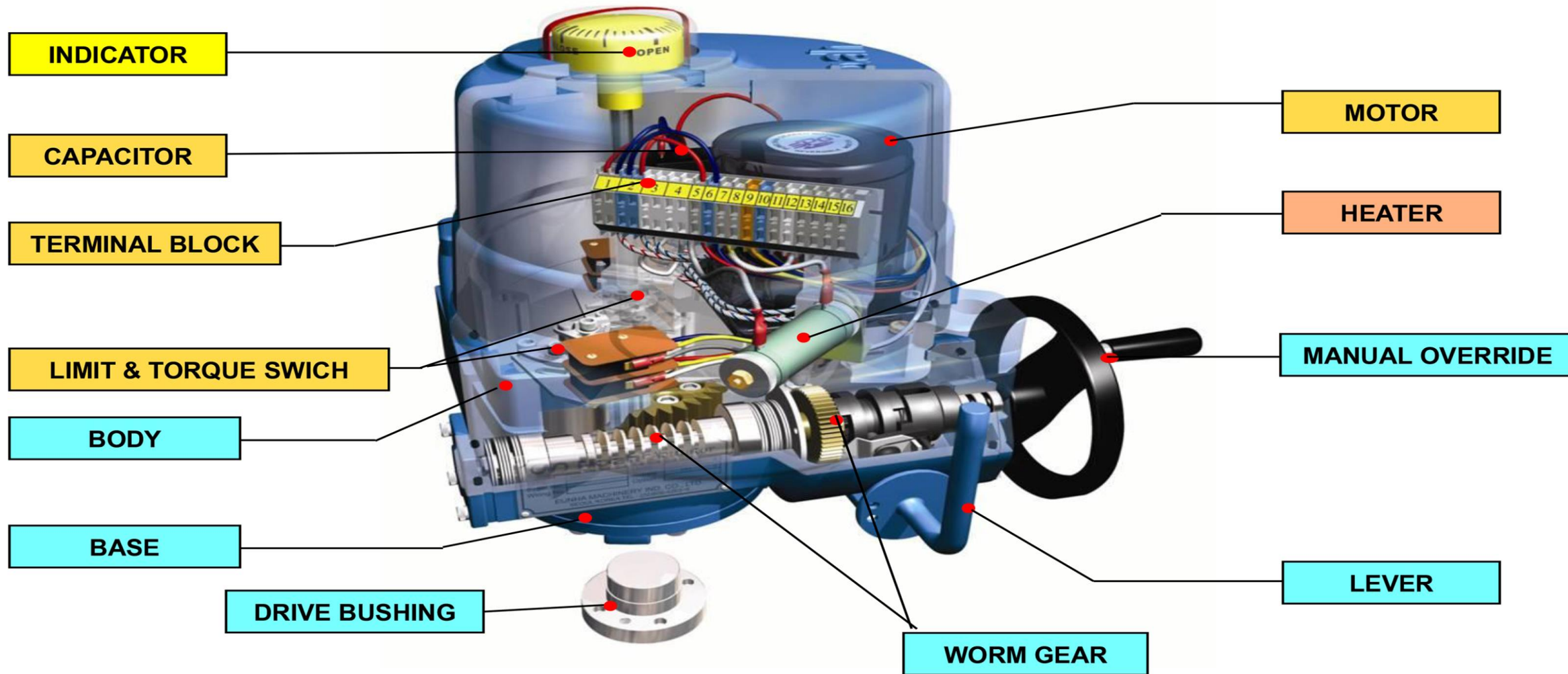



A. MOTOR

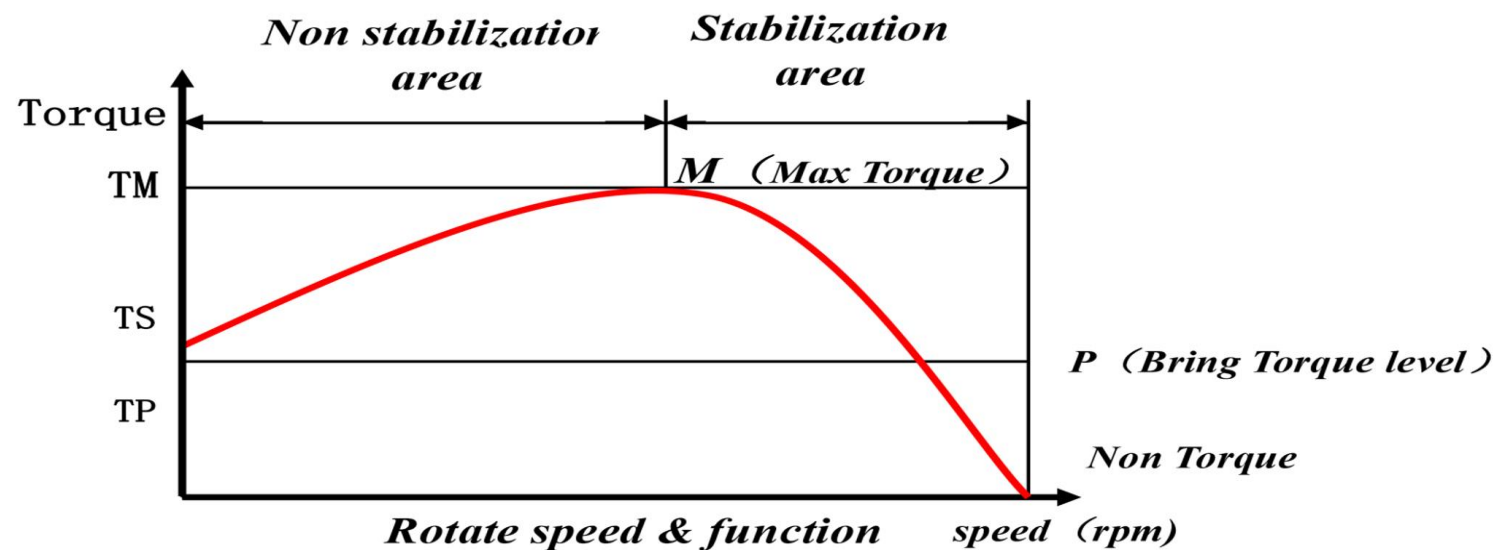

AC Motor

Squirrel caged induction motor is totally enclosed type with high torque and low inertia force to suit seating/unseating of valves. integral thermal protection to prevent damage to the single /three phase motor



B. Worm Gears

The precision worm and worm wheel mechanism transfers high torque and efficiency with low sound level(Max.50dB) even though small in size

(Gear reduction ratio 1462 : 1 ~ 7740 : 1)



First Reduction :

Motor — — 1st Gear — — 1st Gear Wheel



Second Reduction :

2nd Gear — — 2nd Gear Wheel — — Center Column



3th Reduction :

Just use for big output torque products such as 150,200,250

Center Column — — Drive Bushing — — Gear Box — — Valve Shaft



C. Enclosure

- All alloy enclosure is treated by hard-anodized and powder coated.*
- All enclosures are designed to provide IP67 grade protection with explosion proof structure and to provide best performance under any circumstances*

D. Control system

- 1). Terminal Block : This high quality Terminal Block provide best performance under high vibration environments*
- 2). Limit switch : One for open, another one for Close*
As a cam switches structure, It control motor to turn and stop well and truly without any trouble
- 3). Torque switch: Control the output Torque.*
While Actuator get the torque over owns Max rated, it will take the power off to avoid the motor and gears trouble.



E. Space Heater

A space heater be designed inside the Actuator due to temperature and weather changes. It keeps all electrical components in the actuator clean and dry.

F. Indicator

The dome type indicator is directly mounted on the center column to provide positive visual indication of the valve position even over long distances

G. Manual Override

Hand/Auto declutching lever for engagement of hand wheel. The power drive is automatically resorted by the motor starting.



5. Standard Specification

Enclosure	Watertight Ingress Protection IP67 Nema4 and 6
Ambient Temperature	- 20°C ~ + 70°C, 150°C / 1hr
Power Source 50 / 60Hz)	110 / 220VAC 1 Phase ; 380 / 440VAC 3 Phase
Control Power	110 / 220VAC Phase, 50 / 60Hz
Torque Switches	2 Open / Close (Except NA06, NA09)
Limit Switches	2 Open / Close, 250VAC 16A
Stall Protection	Built-in Thermal Protection (Open 150°C±5°C / Close 97°C±15°C)
Travel Angle	90°±5°C
Indicator	Continuous Position Indicator
Manual Override	Hand / Auto Declutching Mechanism
Self Locking	Provided by means of Worm Gearing
Mechanical Stops	External Adjustable screws
Space Heater	20W(110/220VAC, 24VDC)
Conduit Entries	Two PF3 / 4" (NPT 3 / 4")
Lubrication	Grease Moly (EP Type)
Materials	Steel, Aluminum Alloy, All Bronze
Surface Treatment	Anodizing
External Coating	Dry powder, Epoxy-Polyester, Polyester (TGIC-Free)



6. *Optional*

A. Auxiliary Limit Switches (ALS)

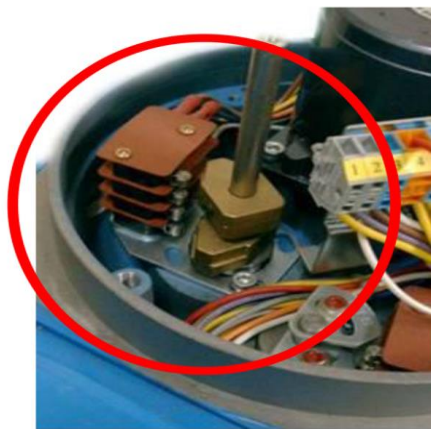

➤ *Providing the dry contact signal to check valve's positions (cam switches structure)*

B. Auxiliary Torque Switches (ATS)

➤ *Providing the dry contact signal send to customer's panel as fault signal (cam switches structure)*

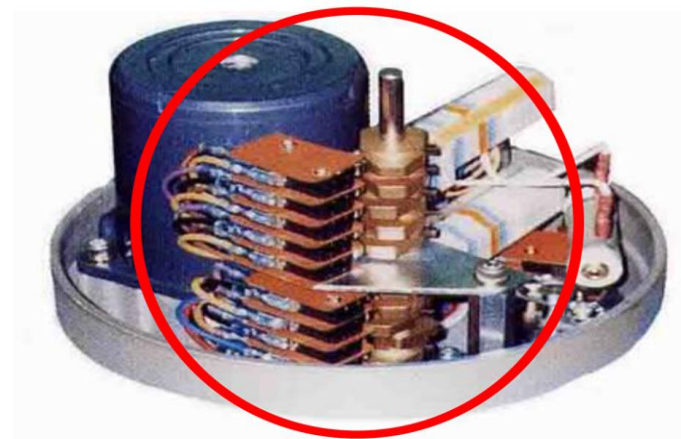



C. Proportional Control Unit (PCU)

➤ *Combined with PIU and control the valve's position proportionally by input signal and provide valve's position as their output signal.*

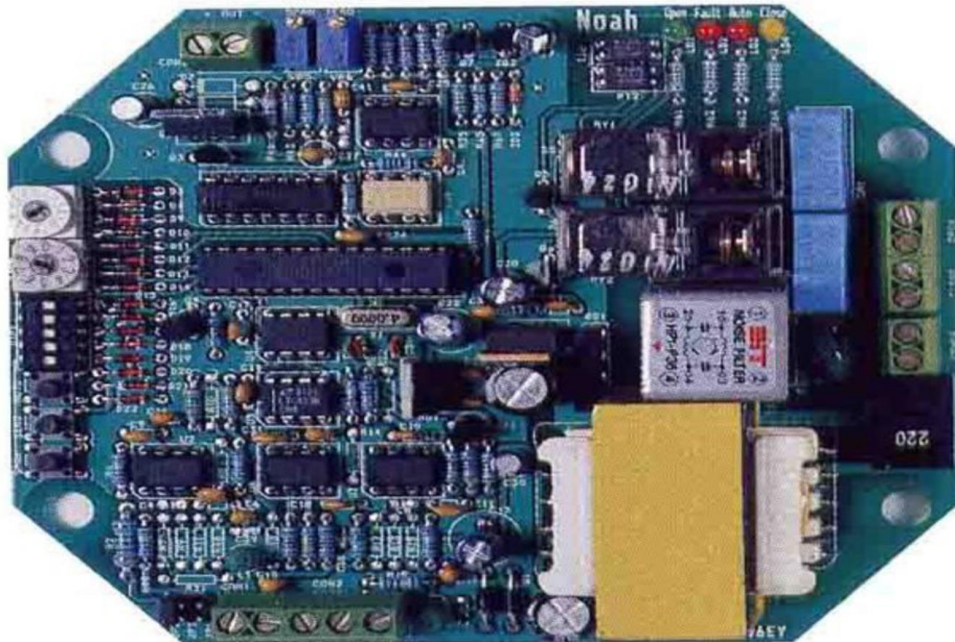

- *Input signal : DC4 ~ 20mA, DC2~10V, DC1~5V*
- *Output signal: DC4 ~ 20mA*
- *Power: AC110/220V ±10% 50 / 60Hz, DC24V*

Applicable Function

- *Auto Scan : Automatically memorized each Open/Close position by the signal of PIU*
- *Fail Close : Drives to close position there is no certain input signal*
- *Fail Open : Drives to open position there is no certain input signal*



D. Position Indication Unit (PIU) and Current Position Transmitter (CPT)

- *Providing resistance value (0~1kΩ) according to valve's position*

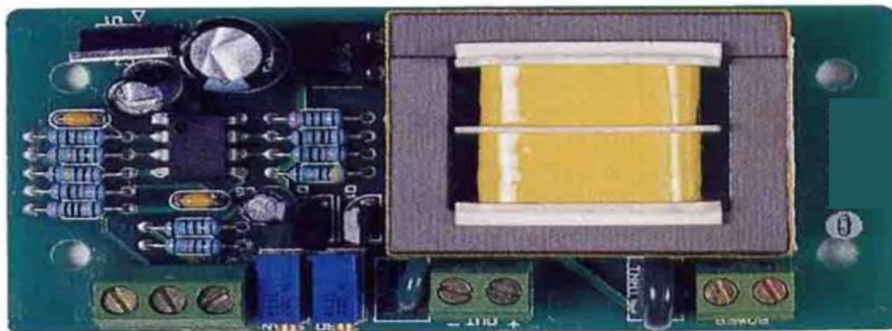
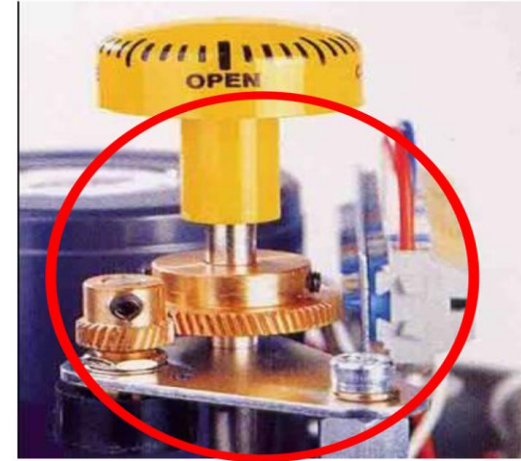

- *Combined with PIU and transfer output signal (DC:4~20mA) from PIU's value of resistance*

*—Power: AC110/220V ±10% 50 / 60Hz,
DC24V*

—Output Signal: DC4~20mA



E. Reversing Magnet Contacts & Transformer (IMS)

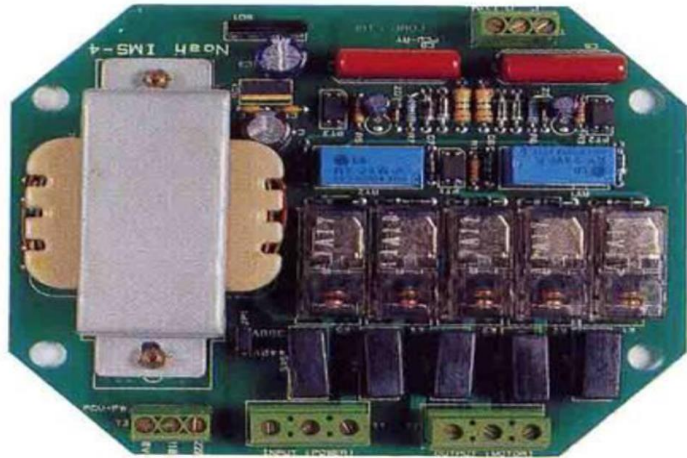

➤ *Combined transformer with electric contactor and directly provides various control voltages to the Actuator(24VDC 110VAC/220VAC)from main power (380VAC/440VAC)*

F. Local Control Unit (LCU)

➤ *A small unit that is mounted to the Actuator to operate the valve's position in local.*

Local/Remote switch

Open/Stop/Close switches





G. Explosion proof & Watertight enclosure Local Control Unit (Exp LCU)

➤ *Rugged structure with special parts (Explosion proof type Selector, pushbutton switches) Guarantees that watertight and safety working in hazardous environments.*



➤ *All fo our explosion proof type products*



Table of available valve size for Actuator

Model	Rating Out Put Torque (Kg.m)	Operating Time		Weight kgf	Piping Pressue: 10kg/cm ²		
		60Hz	50Hz		Butterfly valve	Ball valve (2-way)	Ball valve (3-way)
06	6	14	17	11	80A	40A	
09	9				100A	50A	40A
15	15	17	20	12	125A	65A	50A
19	19			13	150A	80A	65A
28	28	20	24	17	200A	100A	80A
38	38			18	250A		100A
50	50			19		125A	
60	60	24	29	22	300A	150A	125A
80	80			23	350A		150A
100	100			25		200A	
150	150	72	87	68	400/450A		
200	200			70	500A	250A	200A
250	250			70	600A	300A	250A



Testing system of series Electric Actuator

Insulation Test

- For check the insulation status of motor and circuitry

Functional Test

- Running Test (Check up switches, Hand Wheel Turn, Motor's Thermal Protection Unit are on work)*
- Output Signal and Functional Test (Check up Max Output Torque, Traveling Time, Rated Current and Torque Setting)*

Sealing Test

-Check up sealing status of Actuator



Testing procedure

- | | | |
|----------------------------|-----------------------|-------------------|
| ① <i>Electric Actuator</i> | ③ <i>Load cell</i> | ⑤ <i>Computer</i> |
| ② <i>Control box</i> | ④ <i>Load machine</i> | ⑥ <i>Printer</i> |

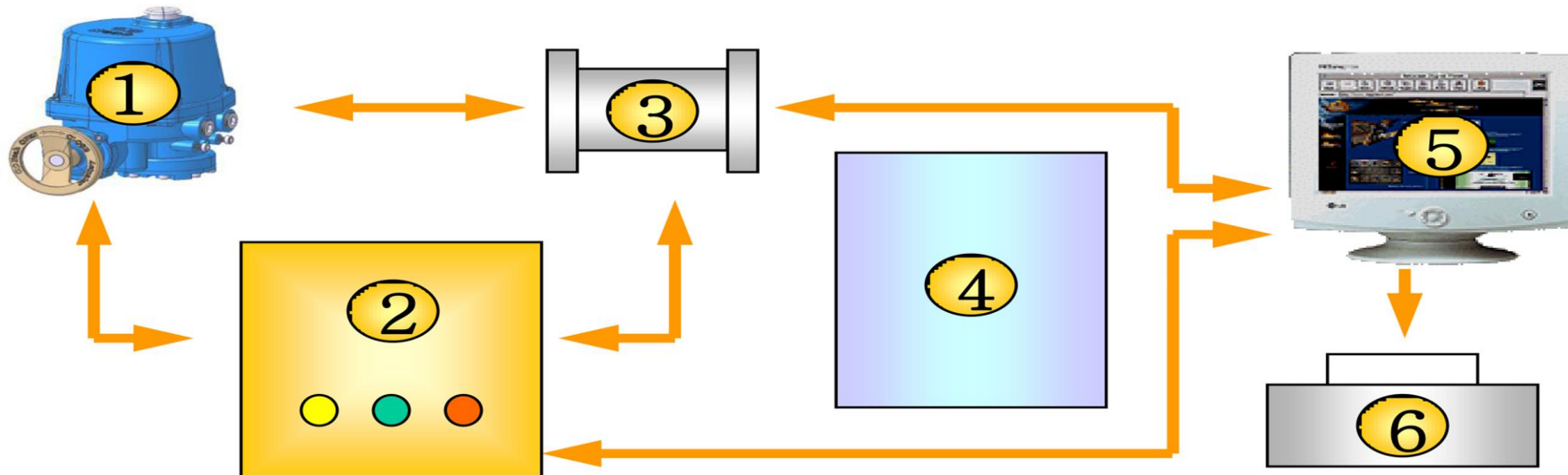



Improvement of the META series products

Dependability

A. Construction's more compact

- Dispose of the clutch level*
- Redesign the 2nd gear*
- Reduce the parts of 1st gear*

B. Improve the parts dependability

- Introduce new plating techniques to increase the parts of service life*

C. Reduce the weight

- Reduce the dimension*
- Change the parts material*
(Introduce plastic material)



New products development

automatism converter for three phase power source

—In case of use three phase power source, It would automatically change the phase to meet the wiring mode ,not need to check the power source's phase up more.

LCD Monitor

—Configure a LCD Monitor in all of our Actuator for make the handle process simply

Smart Electric Actuator

— Provided with the automatically check up and adjust function.

Wireless Control Actuator

—Control the Actuator by wireless mode

Pint-sized Actuator

—Pint-sized and compacted Actuator for under 6kg.m of output torque.



Preview upcoming
model(6kgf-m~9kgf-m)

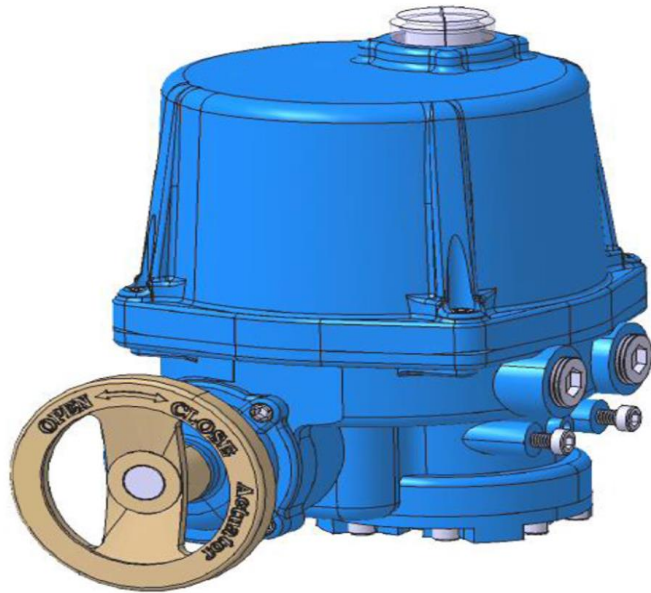

Compact and light weight design

Auto clutch without level

IP68 is standard



Preview upcoming
model(15kgf-m~50kgf-m)

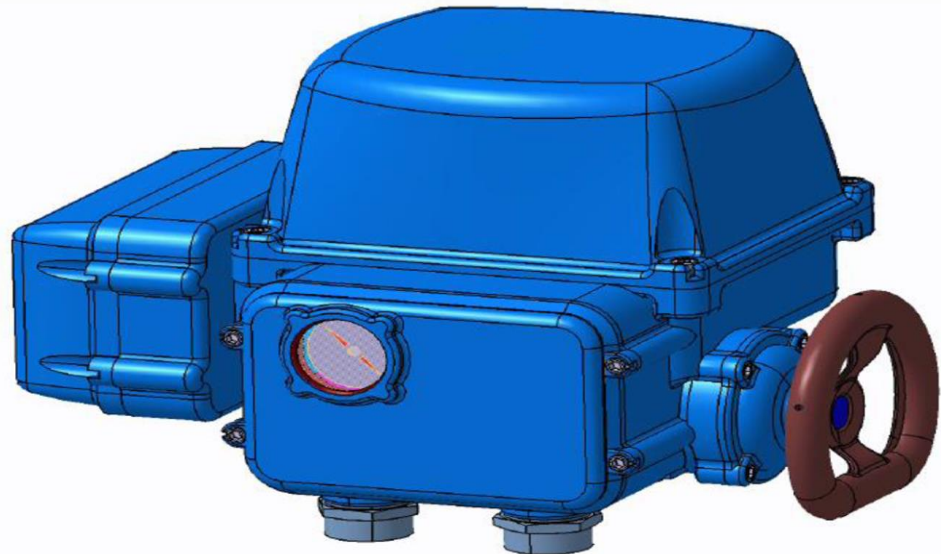

Perfect sealing IP68

Easy wiring & **E**asy limits setting

Auto clutch without level

Aluminum pressure casting



*Thank you for your
patience !*

META